

**ROAD PAVING PROGRAM
NAUGATUCK, CONNECTICUT**

Contract No. 15-12

CONTRACT DOCUMENTS

**PREPARED BY THE
BOROUGH OF NAUGATUCK
CONNECTICUT**

May 2015



BOROUGH OF NAUGATUCK
INVITATION TO BID

Borough of Naugatuck

Sealed bids are invited and will be received by the Purchasing Agent, until 11:00 a.m., Monday June 8, 2015 at the Town Hall, 229 Church Street, Naugatuck, CT and will be publicly opened and read aloud in the Hall of Burgesses, located on the 4th floor for the following:

Contract No. 15-12 Road Paving Program

The Contract Documents may be examined at the Office of the Purchasing Agent, Town Hall, 229 Church Street, Naugatuck, CT 06770.

Copies of Contract documents may be obtained at the Office of the Purchasing Agent upon submission of a non-refundable plan deposit in the form of a check or money order payable to the Borough of Naugatuck in the amount of **\$50.00** per set. Contract Documents can also be obtained at no cost from the Borough of Naugatuck web site <http://www.naugatuck-ct.gov> All firms obtaining Contract Documents from the web site must submit contact information by e-mail to whozer@naugatuck-ct.gov. Contact information must be submitted three days in advance of the bid opening to be considered. Bidders must check the Naugatuck web site to more than three days prior to the bid opening to check for addendums.

The Borough of Naugatuck reserves the right to waive any informalities or to reject any or all bids.

No Bidder may withdraw his bid within (90) days after the actual date of the opening thereof.

AN AFFIRMATIVE ACTION/EQUAL OPPORTUNITY EMPLOYER
MBE's, WBE's and SBE's ARE ENCOURAGED TO APPLY

SPECIFICATIONS

STANDARD SPECIFICATIONS

The material and construction methods for the work specified in this contract shall conform with the applicable provisions of the State of Connecticut, Department of Transportation specifications entitled “*STANDARD SPECIFICATIONS FOR ROADS, BRIDGES AND INCIDENTAL CONSTRUCTION*”, Form 816, 2004, as revised by the Supplemental Specifications up to and including January, 2013 (otherwise referred to collectively as “ConnDOT form 816”) unless modified by the Special Provisions contained herein. “ConnDOT form 816” is hereby made part of this contract. Form 816 may be purchased from:

Connecticut Department of Transportation
Manager of Contracts
2800 Berlin Turnpike, Newington, Connecticut 06111

All references to Commissioner, Department, Engineer, and State anywhere within the Form 816 shall be interpreted to mean the Borough of Naugatuck or a duly authorized agent of the Borough. Any questions or ambiguity regarding any definitions shall be brought to the immediate attention of the Borough.

INDEX TO CONTRACT DOCUMENTS

SECTION

A	Information for Bidders
B	Proposal
C	References/Qualifications
D	Bid Bond / Surety Guarantee Form
E	Contract and Agreement / Certificate as to Corporate Principal
F	Performance Bond
G	Payment Bond
H	Specifications
I	Asphalt Price Adjustments
J	Tentative Paving Schedule
K	Prevailing Wage Rates
L.	Sidewalk Details

SECTION A

INFORMATION FOR BIDDERS

Borough of Naugatuck

Contract No. 15-12; Road Paving Program

1. Proposals Received

Sealed proposals for the Road Improvement Program will be received by the Purchasing Office, Borough of Naugatuck, 229 Church Street, Naugatuck, CT 06770 until Monday, **June 8, 2015, at 11:00 A.M.** local time. Immediately following the bids will be publicly opened and read aloud.

2. Location and Description of Work

These specifications will provide a basis for the furnishing of all materials, equipment, labor, transportation, testing and other goods and services necessary to install complete in place a Bituminous Concrete Pavement consisting of:

- (A) Class I or II surface course, Connecticut Highway Department specification, to be used as a wearing surface and also a Leveling Course as required by the Superintendent of Streets.
- (B) Class I or II - Bituminous Concrete to be used as a Scratch Coat as required by the Superintendent of Streets. All in accordance with special bid terms and conditions attached here with Bituminous Concrete Per Ton in Place. The BOROUGH OF NAUGATUCK reserves the right to increase or decrease the bid quantity at any time.
- (C) Pavement Reclamation – full Depth restoration consist of pulverizing, mixing, fine grading (plus or minus 1 inch of existing material), and rolling to a minimum width of 6 foot and a minimum depth of 12 inches. This operation is including reclaimer; a vibratory roller 10-12 ton; a three (3) axle grader with tandem drive axles over 24,000 lbs; a lead person for grade setting; dust control if needed. All equipment includes operators.
- (D) Full depth Patching of public roadways including saw cutting, excavation and the installation of 12” of process aggregate compacted and bituminous paving as directed.

3. None

4. Specifications

Copies of the Specifications may be seen and obtained at the Purchasing Office, Borough of Naugatuck, 229 Church Street, Naugatuck, CT 06770 The construction contract for the **Contract No. 15-12; Road Paving Program**, will be entered into by the successful bidder and the Borough of Naugatuck. The State of Connecticut Department of Transportation Standard Specifications for Roads, Bridges and Incidental Construction, Form 816 along with supplemental specifications contained herein will detail the general requirements for materials, methods of installation, measurement and basis of payment to be required in this project. Any references to the State of Connecticut, the Department,

the commissioner, Engineer, or other terms indicating the State of Connecticut and her agents as party to the contract shall for this project mean the Borough of Naugatuck and her designated agents or employees.

Where insurance is required to be carried in the name of the State of Connecticut and the State of Connecticut is to be held harmless, this shall be done in the name of the Borough of Naugatuck and the Borough of Naugatuck shall be held harmless.

All requirements for material testing, certificates of the compliance, or material certifications shall be done as if this were a contract being entered into with the State of Connecticut.

It is the intent of this contract to maintain all standard requirements of Form 816 without attempting to redefine every term within the 816 to the "Borough of Naugatuck".

The bidder shall, therefore, be aware that the Borough of Naugatuck and her agents shall inspect and administrate this contract, make contract interpretations, determine the acceptability of the work and approve requests for payments. The Contractor shall be responsible for the requirements stated in Form 816 and in the construction drawings.

5. Addenda and Interpretations

No interpretations of the meaning of the Specifications, or other pre-bid documents will be made to any Bidder orally.

Every request for such interpretation shall be in writing, addressed to Mr. James Stewart, P.E., Borough of Naugatuck, Department of Public Works Office, 246 Rubber Ave. Naugatuck, CT 06770. To be given consideration, such requests must be received at least six (6) days prior to the date fixed for the opening of bids. Any and all such interpretations and any supplemental instructions will be in the form of written addenda to the specifications, which, if issued, will be mailed by certified mail with return receipt requested to all prospective Bidders, at the respective address furnished for such purposes, not later than four (4) days prior to the date fixed for the opening of bids. Failure of any Bidder to receive any such addendum or interpretations shall not relieve such Bidder from any obligation under his bid as submitted. All addenda so issued shall become part of the Contract Documents.

6. Familiarity of the Work

Each Bidder shall fully inform himself prior to bidding as to existing conditions and limitations under which the work is to be performed, and shall include in his bid a sum to cover the cost of items necessary to perform the work as set forth in the Contract Documents. No allowance will be made to a Bidder because of lack of such examination or knowledge. The submission of a bid will be considered as conclusive evidence that the Bidder has made such examination.

The Owner assumes no responsibility whatsoever with respect to ascertaining for the Contractor such facts concerning physical characteristics at the site of the project.

The Contractor agrees that he shall make no claim for and has no right to additional payment or extension of time for completion of the work, or any other concessions, because of any interpretations or misunderstanding on his part of this Contract, or because of any failure on his part to fully acquaint himself with all conditions relating to the work.

Attached to the bid package is a draft list of roads that are proposed to be paved additional roads and locations may be added or removed as needed.

7. None

8. Estimate of Work

For bidding purposes, the work has been subdivided into unit price items. The quantities shown below are to be considered as approximate only. The Inspector does not expressly or by implication agree that the actual quantity(ies) will correspond therewith, but reserves the right to increase or decrease the amount of any Item or portion of the work as may be deemed necessary.

9. Qualification of Bidders

A Bidder shall be a contractor who is experienced in the construction of the projects of this type. The Proposal shall contain adequate proof of the qualifications of the Bidder to perform, in a satisfactory manner and within the time specified, all the work covered by the Plans and Specifications. This proof shall be fully recorded on the pages titled "References", which shall become part of the Proposal.

10. Disqualification of Bidders

More than one proposal from an individual, firm, partnership, corporation, or an association under the same, or different, names will not be considered. Reasonable grounds for believing that any Bidder is interested in more than one proposal for the work contemplated will cause the rejection of all proposals in which such Bidder is interested. Any or all proposals in which such Bidder is interested will be rejected if there is reason for believing that collusion exists among the Bidders; and all participants in such collusion will not be considered in future proposals for the same work. Proposals in which the prices are obviously unbalanced may be rejected. No Contract will be awarded except to competent Bidders capable of performing the class or work contemplated.

11. Preparation of Proposals

The Proposal must be made upon the forms contained herein. The blank spaces in the Proposals must be filled in correctly where indicated. The Bidder must state, both in words and in numerals, written or printed in ink, the prices for which he proposes to do each Item of the work contemplated. In case of discrepancy between the words and the numerals, the words shall govern. Ditto marks are not considered writing, or printing, and shall not be used. The Bidder shall sign his Proposal correctly. If an individual makes the Proposal, his name and post office address must be shown. If made by a firm, partnership, or corporation, the Proposal must be signed by an official of the firm, partnership, or corporation authorized to sign contracts, and must show the post office address of the firm, partnership, or corporation.

Each bid must be submitted in a sealed envelope bearing on the outside the name of the Bidder, this address, and name of the project for which the bid is submitted. If forwarded by mail, the sealed envelope containing the bid must be enclosed in another envelope addressed to: Purchasing Office, Borough of Naugatuck, City Hall, 229 Church Street, Naugatuck, CT 06770.

12. Irregular Proposals

The Borough of Naugatuck reserves the right to reject any proposals if they show any omission, alteration of form, additions not called for, conditional bids, or irregularities of any kind.

13. Proposal Guarantee

No proposal will be considered unless accompanied by a certified check in U.S. dollars,

or bid bond using an insurance company licensed to do business in the State of Connecticut in an amount of \$5,000.00 payable to the order of the Borough of Naugatuck, said check or bid bond to be returned to the Bidder unless forfeited as hereinafter stipulated. Such checks or bid bonds will be returned to all bidders within five (5) days after the execution of the Contract and the furnishing of the required security by the successful Bidder.

14. Withdrawal of Proposals

If a Bidder wishes to withdraw his Proposal, he may do so before the time fixed for the opening of bids by communicating his purpose to the office of the Mayor. Upon such notice, the Proposal will be handed to him unopened.

15. Execution of Contract

The party to whom the Contract is awarded, or his authorized representative, will be required to attend at the office of the Mayor, Borough of Naugatuck, with the sureties offered by him, or them, and a current certificate of Corporate good standing issued by the Office of the Secretary of State in which the corporation is incorporated, and execute the Contract within five (5) days from the date of the award. If the party entering into this contract is a corporation, a Corporate Resolution duly executed by the president and Secretary of the Corporation authorizing the Corporation to enter into this Contract shall be provided. In case of his failure or neglect to do so, the Owner may, at its opinion, determine that the Bidder has abandoned the Contract and thereupon the Proposal and acceptance shall be null and void, and bid security accompanying the Proposal shall be forfeited as liquidated damages to the Owner. If the party entering into this contract is a partnership, a partnership resolution duly executed by a majority of the general partners authorizing the partnership to enter into this contract shall be provided.

16. Bonds

The successful Bidder, at the time of the execution of the Contract, shall furnish a Performance Bond in an amount of \$200,000.00 as security for the faithful performance of this Contract and also a Payment bond in an amount of \$200,000.00 of the Contract prices as security for the payment of all persons performing labor on the project under this Contract and furnishing materials in connection with this Contract. All Bonds shall be in the forms prescribed by Law or Regulation and be acceptable to the Owner. Surety companies executing Bonds must appear on the Treasury Department's most current list (Circular 570 as amended) and be authorized to transact business in the State of Connecticut. Bidder shall provide evidence that Surety Company is licensed to conduct business in the State of Connecticut. All sureties shall be in full force throughout the guarantee period and until the retainage is released.

17. None

18. Responsibility of the Contractor

Attention is hereby particularly directed to the provisions of the Contract and Specifications whereby the Contractor shall be responsible for any loss or damage that may happen in the work, or any part thereof, during its progress and also whereby the Contractor shall make good any defects for faults that may occur within one (1) year after date of final estimate. He shall indemnify and save harmless the Owner and Engineer from any damages or costs to which they may be put by reason of injury to the person or property of another resulting from negligence or carelessness in the performance of the work under this Contract.

19. Insurance

Before execution of the Contract, the Bidder will be required to file with the Borough of Naugatuck a certificate of insurance. The certificate, executed by an insurance company satisfactory to the Borough of Naugatuck shall name the Borough of Naugatuck and the State as additional insured parties on the form furnished with these specifications. The "Certificate of Insurance" shall state that at a minimum, with respect to the contract, the bidder carries insurance in accordance with the requirements and stipulations listed below.

Unless requested otherwise by the Borough of Naugatuck, the Bidder and its insurer shall not assert the defense of governmental immunity in the adjustment of claims or in the defense of any claim or suit brought against the Borough of Naugatuck and the State. The Bidder shall assume and pay all cost and billing for premiums and audit charges earned and payable under the required insurance.

A. Workmen's Compensation Insurance: With respect to all operations the Bidder performs and all those performed for it by subcontractors, the Bidder shall carry workmen's compensation insurance in accordance with the requirements and the laws of the State.

B. Contractor's Public Liability and Property Damage Insurance: With respect to the Project operations the Bidder performs and also those performed for it by subcontractors, the Bidder shall carry regular Contractor's Public Liability Insurance. The insurance shall provide coverage for each accident or occurrence in the amount of \$2,000,000 for all damages resulting from (1) bodily injury to, or death of, persons and/or (2) injury to or destruction of property. Subject to that limit per accident or occurrence, the policy shall provide a total or aggregate coverage of \$2,000,000 for all damages during the policy period.

C. Automobile Liability Insurance: The operation of all motor vehicles, including those hired or borrowed, used in connection with the project, shall be covered by Automobile Liability Insurance. The insurance shall provide coverage for each accident or occurrence in the amount of \$2,000,000 for all damages resulting from (1) bodily injury to, or death of, persons and/or (2) injury to or destruction of property. If an insurance policy shows an aggregate limit as part of the automobile liability coverage, the aggregate limit must be at least \$2,000,000.

D. With respect to the project operations the Bidder performs and also those performed for it by subcontractors, the Bidder shall carry for and on behalf of the Borough of Naugatuck, and State, insurance which shall provide coverage for each accident or occurrence in the amount of \$2,000,000 for all damages resulting from (1) bodily injury to or death of person and/or (2) injury to or destruction of property. Subject to that limit per accident or occurrence, the policy shall provide a total or aggregate coverage of \$2,000,000 for all damages during the policy period.

E. Railroad's Protective Liability Insurance: When the contract involves work on, over or under the right of way of any railroad company, the Bidder shall, with respect to the project operations it performs and also those performed for it by subcontractors, carry Railroad Protective Liability Insurance for and on behalf of the railroad company. The insurance shall provide coverage for each accident and occurrence in the amount of \$2,000,000 for all damages resulting from (1) bodily injury to or death of persons and/or (2) injury to or destruction of property. Subject to that limit per accident or occurrence, the policy shall provide a total or aggregate coverage of \$6,000,000 for all damages during the policy period.

F. Blasting: When explosives are to be used in the prosecution of the work, the insurance required under paragraphs b, d and e above shall also contain provisions for protection, in the amounts state, against damage claims due to such use of explosives.

G. Termination or change of Insurance: Each insurance policy shall be endorsed to provide that the insurance company shall notify the Borough of Naugatuck by certified mail at least thirty (30) days in advance of termination, or any change in the policy. No such change shall be made without prior written approval of the appropriate Official.

H. Claims: Each insurance policy shall state that the insurance company shall agree to investigate and defend the Borough of Naugatuck and State against all damages, even if groundless.

I. Compensation: There shall be no direct compensation allowed the Bidder on account of any premium or other change necessary to take out and keep in effect all insurance or bonds, but the cost thereof shall be considered included in the general cost of the work.

20. Care and Protection of Property

The Contractor shall take particular care to avoid damages to all private property and to private improvements within the Boroughs' right of way. He shall make good any damages to the satisfaction of the Inspector. There shall be no additional compensation for the repair or restoration of private property, or private improvements, within the Boroughs' right of way.

21. Sales Tax

Certain materials and supplies incorporated in the work of this project are exempt from Connecticut Sales Tax. The Bidder shall familiarize himself with current regulations of the State Tax Department. The tax on materials or supplies exempted by such regulations shall not be included as part of the bid. The Owner will furnish the successful Bidder a sales tax exemption number.

22. Compliance with Federal and State Regulations

The Contractor shall be responsible for full compliance with any Federal and/or State laws, regulations and standards, as applicable to any project fully or partially funded by State and/or Federal funding agency. This project is funded, in part, by the State and Federal government.

23. Permits

All licenses and permits for complying with any applicable Federal, State, and Municipal laws, codes and regulations in connection with the prosecution of the work shall be obtained by the Contractor, at no additional cost to the Owner.

24. Sedimentation and Erosion Control Plan

The Contractor shall prepare a sedimentation and erosion control plan for the work if applicable.

25. Contractor's Right to Terminate Work

If the work should be stopped under an order of any court or other public authority, for a consecutive period of not less than thirty (30) days, through no act or fault of the Contractor or of anyone employed by him, then the Contractor may terminate this Contract and recover from the Owner payment for all work executed.

26. None

27. Power of Attorney

Attorneys-in-fact who sign contract bonds must file, with each bond, a certified and effectively dated copy of their power of attorney.

28. Right to Reject

The Owner reserves the right to reject any or all proposals or to accept any bid, should it deem it to be in the best interest of the Owner

29. Prevailing Wage Rates:

- A. Prevailing wage rates shall apply to this contract
- B. The minimum wage rates, health, welfare and pension fund contributions are as determined by the State of Connecticut in accordance with the provisions of Section 31-53/31-54 of the Connecticut General Statutes.
- C. The minimum current wage and benefit rates are set forth in the wage schedule (attached to the Bid Package). The Contractor will be bound and obligated by the Laws of Connecticut to insure payment to all workers involved with construction of this said Project.
- D. Certified payroll reports must be submitted to the Town.

Road Paving Program

SECTION B

PROPOSAL

The undersigned, as Bidder, declares that no person or persons, other than those named herein, are interested in this Proposal; that this Proposal is made without collusion with any person, firm or corporation; that he has carefully examined the location of the proposed work, the proposed Form of Contract, and the Contract Drawings therein referred to; that no person or persons acting in any official capacity for the Owner is directly or indirectly interested therein or in any portion of the profit thereof; and that he proposes and agrees, if this Proposal is accepted, to execute the Form of Contract with the Owner; to provide all necessary equipment, tools, and other means of construction, and to do all work and furnish all materials specified in the Contract, in the manner and time therein prescribed, and according to the requirements of the Borough of Naugatuck Inspector as therein set forth, and that he will take in full payment therefore, the following unit prices and lump sums, to wit:

The Bidder acknowledges receipt of the following addenda:

Addendum No. _____ Dated: _____

Addendum No. _____ Dated: _____

The undersigned agrees that he shall execute the Contract within the ten (10) days after the date of award, and shall commence work within the ten (10) days after date of the Notice to Proceed and shall progress therewith to its entire completion within the time stipulated in the Contract.

The Bidder agrees that this bid shall be good and may not be withdrawn for a period of ninety (90) days after the scheduled closing time for receiving bids.

If this Proposal shall be accepted by the Owner and the undersigned shall fail to contract as aforesaid, and to give bonds as required, as determined by the canvass of bids, and with surety or sureties satisfactory to the Owner within ten (10) days from the date of the award, then the Owner may, at its option, determine that the Bidder has abandoned the Contract: thereupon, the Proposal and acceptance shall be null and void, and the bid security, accompanying this Proposal, shall become the property of the said Owner as liquidated damages for the delay and additional expense to the Owner caused thereby if said Proposal shall be rejected, or if said Proposal shall be accepted and the Bidder shall execute and deliver a contract in the Form of Contract attached hereto (properly completed in accordance with said Proposal) and shall furnish a Bond for his faithful performance of said Contract, and for the payment of all persons performing labor or furnishing materials in connection therewith, and shall in all other respects perform the agreement created by the acceptance of said Proposal, the accompanying bid security shall be returned to the undersigned making bid.

Road Paving Program

PROPOSAL continued

The undersigned is aware that the Borough of Naugatuck may reject any and all bids in whole or in part; that the Borough may waive technical defects, irregularities and omissions; that the award will be based on the combination of items that will best serve the interest of the Borough; that the bid price does not include any taxes for which the Borough is not liable; and that acceptance of the bid will establish no exclusive contract by which the Borough of Naugatuck will be required to purchase from the undersigned.

The undersigned claims without reservation that his/her bid is made without collusion with any other person, individual or corporation.

Bid Item quantities for unit price bid items are not guaranteed. Final payment will be based on actual installed quantities. Items not specifically identified for payment in the Bid Form shall be assumed to be included in the work effort of other bid items and shall not be paid or requested for payment separately.

Longitudinal Joint Construction Methods: Unless noted on the plans or the contract documents or directed by the Engineer, the Contractor shall use Method II Butt Joint (see figure 4.06-2) shall be used for all work.

The Contractor shall not be responsible for providing formal Inspection, Sampling or Testing for this work. The Contractor shall be responsible to meet all quality specification herein.

Company Name: _____

Address: _____

Town: _____

Telephone: _____

Email: _____

Agent Name: _____

Agent Signature: _____

Road Paving Program
PROPOSAL continued

BITUMINOUS CONCRETE MATERIALS COMPLETE IN PLACE

CLASS 01 - 02

500 - 4,999 Tons: Class 01 \$ _____ / per ton Class 02 \$ _____ /per ton

5,000 Tons & over: Class 01 \$ _____ / per ton Class 02 \$ _____ /per ton

Hand / Sidewalks / Aprons: \$ _____ / per ton

Leveling Course: \$ _____ / per ton

Tack Coat per gallon: \$ _____ / per gallon

Asphalt Curbing : \$ _____ / per linear foot.

1. Asphalt price adjustments will not apply to asphalt curbing, tack Coat, or hand/ sidewalk, or aprons and are be based on the April 2015 average of the F.O.B. terminal price per ton of unmodified PG 64-22 binder without anti-stripping agent (base average F.O.B. terminal price). The April 2015 average shall be \$505.00 per ton. The bid # shall be based on this number.

The following Bid Items may be used as part of the contract work will generally take place on provided street list. The Borough may award to multiple contractors depending on the bids provided.

Pavement Reclamation

1500 – 5000 SY \$ _____ /per SY

½ Day Rate \$ _____ /per ½ Day

Full Day Rate \$ _____ /per Full Day

Road Paving Program
PROPOSAL continued

Full Depth Patching

10-50 SY	\$ _____/per SY
51-200 SY	\$ _____/per SY
201-500 SY	\$ _____/per SY
Over 500 SY	\$ _____/per SY

Full Depth Patching shall include:

- A. Saw cutting as directed.
- B. Excavation to 16” below grade, and disposal of all material
- C. Compaction of subgrade
- D. Installation of 12” of crushed gravel M.02.06 Grading B
- E. Installation of Bituminous Asphalt paving 2-2” lifts Compacted. (Paving shall be paid under the Hand work paving Item)

Catch Basin Top Replacement

Replace Catch Basin Top Type C & CL Top \$ _____/ EA

Catch Basin Top Replacement shall include:

- A. Saw cutting as directed.
- B. Excavation as required, and disposal of all material
- C. Compaction of subgrade
- D. Installation of crushed gravel M.02.06 Grading B
- E. Installation of Bituminous Asphalt paving 2-2” lifts Compacted & Curbing. (Paving shall be paid under the Hand work paving Item)
- F. Catch basin tops shall be supplied and delivered by the Borough of Naugatuck.
- G. CB block, brick and Mortar Shall be the supplied by the Contractor.
- H. Installation CB top and repair of 6” of catch basin block/brick as required.

Road Paving Program
PROPOSAL continued

Catch Basin Repair 6' to 4'

Repair Catch Basin Structure \$ _____/ Vertical FT

Catch Basin Repair 6' to 4' shall include:

- A. Saw cutting as directed.
 - B. Excavation as required, and disposal of all material
 - C. Compaction of subgrade
 - D. Installation of crushed gravel M.02.06 Grading B
 - E. Installation of Bituminous Asphalt paving 2-2" lifts Compacted & Curbing. (Paving shall be paid under the Hand work paving Item)
 - F. Catch basin tops replacement shall be paid under catch basin top replacement item.
 - G. CB block, brick and Mortar Shall be the supplied by the Contractor.
 - H. Repair of Catch Basin as required and as directed.
-

Installation of Handicapped Ramps And Associated Sidewalk 8 to 20 SY

Handicapped Ramps and associated sidewalks \$ _____/ SY

Installation of Handicapped Ramps and Associated Sidewalks 8 to 20 SY shall include:

- A. Saw cutting as directed.
 - B. Excavation as required, and disposal of all material
 - C. Compaction of subgrade
 - D. Installation of crushed gravel 6" M.02.06 Grading B
 - E. Installation of Monolithic Concrete sidewalks as per details including detectable warning surface.
 - F. Installation of Bituminous Asphalt paving 2-2" lifts Compacted & Curbing. (Paving shall be paid under the Hand work paving Item)
 - G. Topsoil and turf establishment.
-

Road Paving Program
PROPOSAL continued

Installation Sidewalks including Handicapped Ramps 21 to 500 SY

Installation Sidewalks including Handicapped Ramps 21 to 500 SY \$ _____/ SY

Installation of Handicapped Ramps and Associated Sidewalks 21 to 500 SY shall include:

- A. Saw cutting as directed.
- B. Excavation as required, and disposal of all material
- C. Compaction of subgrade
- D. Installation of crushed gravel 6" M.02.06 Grading B
- E. Installation of Monolithic Concrete sidewalks and detectable warning surface as per details.
- F. Installation of Bituminous Asphalt paving 2-2" lifts Compacted & Curbing. (Paving shall be paid under the Hand work paving Item)
- G. Topsoil and turf establishment.

SECTION C

REFERENCES/QUALIFICATIONS

The Bidder is required to fill out the following form to enable the Owner to make inquiries and judge as to the Bidder's experience, skill, available financial resources, credit, and business standing.

1. Number of years the bidder has been in business as a General Contractor: _____

2. Has the Bidder ever failed complete work awarded; and if so, state where and why:

3. Does the Bidder plan to sublet any part of this work; and if so, give details:

4. List equipment Bidder owns that is available for this project:

5. List equipment the Bidder plans to rent or purchase for this project:

Major Material Supplier: _____

Bidder

BOROUGH OF NAUGATUCK

CONTRACTOR'S QUALIFICATION SUMMARY
Road Paving

The bidder is required to submit this summary with his bid in order that the Borough of Naugatuck may properly evaluate the qualifications of the Contractor. Failure to submit this summary in proper form will be cause of rejection of the bid. .

List projects below:

Owner's Name	Year Completed	Project Number	Tons	Person to Contact Name/Telephone

VENDOR NAME: _____

SECTION D

BID BOND /SURETY GUARANTY

BID BOND

KNOW ALL MEN BY THESE PRESENTS, that we the undersigned:

as Principal, and _____ as Surety are held and firmly bound unto Borough of Naugatuck hereinafter called the "Owner", in the penal sum of _____ Dollars, (\$ _____) lawful money of the United States, for the payment of which sum well and truly to be made, we bind ourselves, our heirs, executors, administrators, successors, and assigns, jointly and severally, firmly by these presents.

THE CONDITIONS OF THIS OBLIGATION IS SUCH, that whereas the Principal has submitted the accompanying BID, dated _____, 20____, for _____

NOW THEREFORE, if the Principal shall not withdraw said Bid within the time period specified therein after the opening of the same, or within any extended time period agreed to by the Principal, Surety and Owner, or, if no period be specified, within ninety (90) days after the said opening, and shall within the period specified thereof, or if no period be specified, within twenty (20) days after the prescribed forms are presented to him for signature, enter into a written Contract with the Owner in accordance with the Bid as accepted, and give bond with good and sufficient surety or sureties, as may be required, for the faithful performance and proper fulfillment of such Contract; then the above obligation shall be null and void and of no effect, otherwise to remain in full force or virtue.

Failure to comply with the aforementioned condition shall result in the forfeiture of this BID BOND as liquidated damages.

IN WITNESS WHEREOF, the above-bounded parties have executed this Instrument under their several seals this _____ day of _____, 20____, the name and corporate seal of each corporate party being hereto affixed and these presents signed by its undersigned representative, pursuant to authority of its governing body.

No extension of time or other modification of the BID BOND shall be valid unless agreed to in writing by the parties to this Bond.

BID BOND
(Page 2 of 2)

In presence of:

(Individual Principal)

(Business Address)

(Individual Principal)

(Business Address)

Attest:

(Corporate Principal)

(Business Address)

By:

Affix
Corporate
Seal

Attest:

(Corporate Surety)

(Business Address)

By:

Affix
Corporate
Seal

Countersigned

By: _____

* Attorney-in Fact, State of _____

* Power-of Attorney for person signing for Surety Company must be attached to Bond.

SURETY GUARANTY FORM

(To accompany Proposal)

KNOW ALL MEN BY THESE PRESENTS, that for and in consideration of the sum of \$1.00, lawful money of the United States, the receipt whereof is hereby acknowledged, paid the undersigned corporation, and for other valuable consideration, the _____
_____ a

(Name of Surety Company)

corporation organized and existing under the laws of the State of _____ and licensed to do business in the State of Connecticut, certifies and agrees, that if the Contract for the Road Paving Program is awarded to _____, the undersigned corporation will execute the

(Name of Bidder)

bond or bonds as required by the Contract Documents and will become Surety in the full amount of the Contract Price for the faithful performance of the Contract and for payment of all persons supplying labor or furnishing materials in connection therewith.

(Surety)

(To be accompanied by the usual proof of authority of officers of Surety Company to execute the same.)

SECTION E

CONTRACT AGREEMENT AND CERTIFICATE AS TO CORPORATE PRINCIPAL

CONTRACT AND AGREEMENT

THIS AGREEMENT, made this _____ day of _____ in the year 20____,
Between the Borough of Naugatuck, with its principal office and place of business at 229
Church Street, Connecticut 06770, acting herein through it's Mayor and
_____, a _____, with an office and
place of business at _____, hereinafter called the contractor.

WITNESSETH: That the parties to this agreement in consideration of the undertakings,
promises, and agreements on the part of the other herein contained, hereby undertake, promise,
and agree as follows:

I Definitions

The word "Owner" as used herein shall mean the Borough of Naugatuck, acting through
its properly authorized representatives.

The words "as directed", "as required", "as permitted", "as allowed", or phrases of like
effect or import, used herein shall mean that the direction, requirement, permission, or allowance
of the Borough of Naugatuck Inspector is intended and similarly the words "approved",
"reasonable", "suitable", "proper", "satisfactory", or words of like effect or import, unless
otherwise particular specified herein, shall mean approved, reasonable, suitable, proper, or
satisfactory in the judgement of the Borough of Naugatuck Inspector.

The word "Contractor" shall mean _____ or it's duly authorized agents.

II Contract Includes

The indices, headings and subheadings are for convenience only and do not form a part of
the Contract Documents.

The Contractor shall, at his own sole cost and expense, furnish all labor, materials, and
other services necessary for the completion of this Contract and shall complete and finish the
same in the most thorough, workmanlike, and substantial manner, in every respect, to the
satisfaction and approval of the Borough of Naugatuck Inspector, in the manner and within the
time hereinafter limited, and in strict accordance with the Advertisement, Information for
Bidders, Proposal, General Requirements, Detailed Specifications, and Addenda hereto attached,
and the Contract Drawings herein referred to, (collectively the "contract documents"), which
contract documents are hereby made a part of this Contract as fully as if the same were repeated
at length herein.

Addendum No. ____	Dated: _____	Addendum No. ____	Dated: _____
Addendum No. ____	Dated: _____	Addendum No. ____	Dated: _____
Addendum No. ____	Dated: _____	Addendum No. ____	Dated: _____

III Specifications and Contract Drawings Supplementary

The said Specifications and Contract Drawings are intended to supplement each other, and together constitute one complete set of Specifications and Contract Drawings, so that any work exhibited in the one and not in the other shall be executed just as if it had been set forth in both, in order that the work shall be completed in every respect according to the complete design or designs as decided and determined by the Borough of Naugatuck Inspector. Should anything be omitted from the Specifications and Contract Drawings, the Contractor shall promptly notify the Borough of Naugatuck Inspector. From time to time during the progress of the work, the Borough of Naugatuck Inspector will furnish such supplementary or working drawings as are necessary to show changes or define the work in more detail, and these also shall be considered as Contract Drawings. When discrepancies exist between the Contract Drawings and Specifications, the Specifications shall govern.

IV Modifications

The Contractor, in entering into this Contract, understands that the Owner reserves the right to modify, to the extent herein provided, the arrangement, character, grade, or size of the work or appurtenances whenever, in the Owner's opinion, it shall be deemed necessary or advisable to do so. Minor changes in the work, not involving extra cost and consistent with the purposes of the work, may be made by verbal order, but no modifications involving extra work or material changes shall be made unless ordered in writing by the Borough of Naugatuck Inspector; and if the modification requires additional cost, a purchase order must be issued prior to work commencing. The Contractor shall and will accept such modifications when ordered in writing by the Owner through the Borough of Naugatuck Inspector, and the same shall not vitiate or void this Contract.

Any such modifications so made shall not, however, subject the Contractor to increased expense without equitable compensation, which shall be determined by the Borough of Naugatuck Inspector. If such modifications result in a decrease in the cost of work involved, and equitable deduction from the Contract price, to be determined by the Borough of Naugatuck Inspector, shall be made. The Borough of Naugatuck Inspector's determination of such additional compensation, or of any such deduction, shall be based upon the unit prices in the Contractor's bid, unless the modification involves work not included in such bids and then in the event, the modification shall be as set forth in Section XXVIII prior to the commencement of additional work. In no event shall any modification in the work shown on the Plans and Specifications be made unless the nature and extent thereof has first been certified by the Borough of Naugatuck Inspector in writing and sent to the Contractor.

V Correction of Errors and Omissions

The Plans and Specifications forming part of this Contract are intended to be explanatory of each other, but should any discrepancy appear, or misunderstanding arise, as to the import of anything contained in either, the explanation and decision of the Borough of Naugatuck Inspector shall be final and binding on the Contractor; and all directions and explanations required, to complete and make effective any of the provisions of the Contract and Specifications, shall be given by the Borough of Naugatuck Inspector. Corrections of errors and omissions in the Drawings or Specifications may be made by the Borough of Naugatuck Inspector when such corrections are necessary for the proper fulfillment of the Contract Documents as construed by the Borough of Naugatuck Inspector. The effect of such corrections shall date from the time that the Borough of Naugatuck Inspector gives due notice thereof to the Contractor.

VI Borough of Naugatuck Inspector's Decision

All work under this Contract shall be done to the satisfaction of the Borough of Naugatuck Inspector, who shall determine the amount, quality, acceptability, and fitness of the several items of work and materials which are to be paid for hereunder. He also shall decide all questions which may arise as to the fulfillment of the terms of the Contract, Plans and Specifications. The determination of the Borough of Naugatuck Inspector in all such matters shall be final and binding upon the parties thereto.

VII Inspection of Work

It is agreed that the Owner may, at its pleasure, appoint and employ, at its own expense, such persons as may be necessary, who are to act as Borough of Naugatuck Inspectors, inspections, or agents, for the purpose of determining, in the Borough's interest, that the materials furnished and the work done, as the work progresses, conforms to the requirements of the Contract Documents. Such persons shall have unrestricted access to all parts of the work and to other places at and where the preparation of the materials and other parts of the work to be done under this Contract are carried on and conducted. They shall be given, by the Contractor, all facilities and assistance required to carry out their work of inspection.

It is not the function of the Borough of Naugatuck Inspector to supervise or direct the manner in which the work to be done under this Contract is carried on or conducted. The Borough of Naugatuck Inspector is not responsible for construction means, methods, techniques, sequences, or procedures, or for safety precautions and programs in connection with the work, and he will not be responsible for the Contractor's failure to carry out the work in accordance with the Contract Documents.

The Borough of Naugatuck Inspector shall have authority to reject and shall reject any work or material, or any part thereof, which does not, in his opinion, conform to the Contract Drawings, working drawings, Specifications, and Contract, and it shall be permissible for him to do so at any time during the progress of the work.

No work shall be done except in the presence of the Borough of Naugatuck Inspector or his assistants. No material of any kind shall be used upon the work until it has been inspected and accepted by the Borough of Naugatuck Inspector. Any materials or workmanship found at any time to be defective, or not of the quality or character required by the Contract Drawings and Specifications, shall be remedied at once regardless of previous inspection.

Such inspection shall not relieve the Contractor from any obligation to perform said work strictly in accordance with the Contract Drawings and Specifications, and work not so constructed shall be removed and made good by the Contractor at this own expense and free of all expense to the Owner, whenever so ordered by the Owner, without reference to any previous oversight or error in inspection.

VIII Address of Contractor

The address in the Proposal, upon which this Contract is based, shall be the place. The delivering at the above-named place of any such notice, letter, or other communication where notices, letters or other communications to the Contractor may be mailed or delivered, from the Borough to the Contractor, the date of said service shall be the date of such delivery. Nothing herein contained shall be deemed to preclude or render inoperative the service of any notice, letter, or other communication upon the Contractor personally.

IX Obligation of the Contractor

The Contractor shall, at his own expense, provide any and all manner of supervisor, insurance, taxes, labor, materials, apparatus, scaffolding, appliances, tools, machinery, power, transportation, and whatever else may be required of every description necessary to do and complete the work and shall be solely answerable for the same and for the safe, proper, and lawful construction, maintenance, and use thereof. The Contractor shall cover and protect the work from damage and shall make good all injury to the same occurring before completion of this Contract. The Contractor shall employ only competent workmen and shall provide experienced superintendents and foremen on each part of the work.

The Contractor shall, at its own expense, wherever necessary or required, maintain fences, provide watchmen, maintain lights, place additional timber and braces, and take such other precautions as may be necessary to protect life, property, and structures, vehicles and pedestrians and shall be liable for all damages, occasioned in any way by his act or neglect or that of this agent, employees, or workmen. He shall provide access at all times to private property.

X Occupational Safety and Health Act

The applicable sections of the Occupational Safety and Health Act of 1970 (Williams-Steiger Act) shall apply and be made a part of this Contract. The Contractor's attention is particularly directed to the record keeping requirements of this Act.

XI Nondiscrimination in Employment

The Contractor agrees and warrants that, in the performance of this Contract, he will not discriminate or permit discrimination against any person or group of persons on the grounds of race, color, sex, religion, or national origin in any manner prohibited by State, Federal, County or Municipal law.

XII Personal Attention and Competent Workmen

The Contractor shall give his personal attention constantly to the faithful prosecution of the work and shall be present, either in person or by a duly authorized representative, on the site of the work continually during its progress to receive directions or instructions from the Borough of Naugatuck Inspector. The Contractor shall employ at the site, during the performance of the work, a competent superintendent or foreman who shall be satisfactory to the Borough of Naugatuck Inspector and who shall not be changed, except with the consent of the Borough of Naugatuck Inspector, unless he shall cease to be an employee of the Contractor. Such superintendent or foreman shall represent and have full authority to act for the Contractor in his absence, and all directions and instructions given such superintendent or foreman shall be as binding as if given to the Contractor.

The Contractor shall employ only competent, skillful men to do the work, and whenever the Borough of Naugatuck Inspector shall notify the Contractor in writing that any man on the work is, in his opinion, incompetent, unfaithful, disorderly, or otherwise unsatisfactory, such man shall be discharged from the work and shall not again be employed on it, except with the consent of the Borough of Naugatuck Inspector.

XIII Public Safeguards

The Contractor agrees to conduct the work at all times in such a manner that public travel shall not be inconvenienced needlessly nor shall it be wholly obstructed at any point.

XIV Materials and Workmanship

It is the intent of the Specifications to describe fully and definitely the character of materials and workmanship furnished regarding all ordinary features and to require first-class work and materials in all particulars. For any unexpected features arising during the progress of

the work and not fully covered herein, the Specifications shall be interpreted by the Borough of Naugatuck Inspector to require first class work and materials in all respects, and such interpretation shall be accepted by the Contractor.

XV Materials and Manufactured Articles

All materials and workmanship shall be subject to the approval of the Borough of Naugatuck Inspector and shall be in conformity with approved modern practice.

Unless otherwise specifically provided for in the Specifications, all materials incorporated in the work shall be new, of standard and first-class quality, and of the best workmanship and design. No inferior, or low grade, material will be either approved or accepted, and all work of assembly and construction must be done in a neat, first-class, and workmanlike manner.

XVI Unnoticed Defects

The inspection of the work and materials by the Borough of Naugatuck Inspector shall not relieve the Contractor of any of his obligations to fulfill this Contract, as herein described, and defective work shall be made good and unsuitable materials shall be rejected, notwithstanding that such work and materials had been previously overlooked by the Borough of Naugatuck Inspector and accepted or estimated for payment. If the work, or any part thereof, shall be found defective at any time before final acceptance of the whole work, the Contractor shall forthwith make good such defects, in a manner satisfactory to the Borough of Naugatuck Inspector.

XVII Care and Protection of Work

From the commencement of the work until the completion of the same, the Contractor shall be solely responsible for the care of the work covered by the Contract and for the materials delivered at the site intended to be used in the work; and all injury, damage, or loss of the same, from whatever cause, shall be made good at his expense before the final estimate is made. He shall provide suitable means of protection for all materials intended to be used in the work and for all work in progress as well as for completed work. He shall take all necessary precautions to prevent injury or damage to the work under construction by flood, freezing or inclement weather at any and all times. The methods used for this purpose shall be subject to the approval of the Borough of Naugatuck Inspector, but shall not relieve the Contractor from liability for inadequate protection of the work or materials.

XVIII Assignment of Contract

The Contractor shall have no right or power to assign this Contract, in whole or in part, nor to assign any right arising, or moneys due or to grow due thereunder, without prior written approval of the Owner.

XIX Subcontracting

The Contractor may utilize the services of specialty subcontractors on those parts of the work which, under normal contracting practices, are performed by specialty subcontractors. The Contractor shall not award the work to a subcontractor(s) without prior written approval of the Owner. The Contractor shall be fully responsible to the Owner for the acts and omissions of his subcontractors, and of persons either directly or indirectly employed by them, as he is for the acts and omissions of persons directly employed by him.

The Contractor shall cause appropriate provisions to be inserted in all subcontracts relative to the work to bind subcontractors to the Contractor by the terms of these Contract Documents, insofar as applicable to the work of subcontractors, and to give the Contractor the same power as regards terminating any subcontract that the Owner may exercise over the Contractor under any provisions of these Contract Documents.

Nothing contained in this contract shall create any contractual relation between any subcontractor and the Owner.

XX Liability of Contractor for Employees

Each and every employee of the Contractor and each and every of his subcontractors engaged in the said work shall, for all purposes, be deemed and taken to be the exclusive servants of the Contractor and not for any purpose or in any manner in the employment of the Owner. The Contractor shall, in no manner, be relieved from responsibility or liability on account of any fault or delay in the execution of the said work, or any part thereof, by any such employee, or any such subcontractor, or any material men, whatsoever.

XXI Coordination With Other Contractors and Utilities

During the progress of the work, existing utilities may be found to be in close proximity to or in conflict with the work being installed. The Contractor shall make every effort to identify and locate these utilities before working in the area. If it is known or found that these utilities exist the Contractor shall contact the appropriate utility and alert them to the situation. Should an existing utility be found to be in close proximity to the work the Contractor shall take all the necessary precautions to protect the utilities and his work. Should existing utilities be found to conflict with the work the Contractor shall arrange with the utility company for their adjustment. No additional compensation will be made for delays, inconvenience or damage sustained by the Contractor due to interference from the above-noted utility appurtenances or the operation of locating, installing or moving them or the inability of others to perform their work in a timely manner.

XXII Permits, Laws, Codes, Ordinances and Insurance

The Contractor shall keep himself fully informed of all existing and current codes, ordinances, and regulations and Municipal, County, State or National laws in any way limiting or controlling the actions or operations of those engaged upon the work or affecting the materials supplied to or by them. He shall, at all times, observe and comply with all such valid and legally binding ordinances, laws, and regulations and shall protect and indemnify the Owner and its representatives and agents against any claim or liability arising from, or based on, any violation of the same. He shall obtain and pay for all necessary permits and pay all fees required in connection with the Contract. Contractor shall provide the types and amounts of insurance as set forth in Section 19, Information of Bidders and maintain in effect. He shall take out and carry appropriate employer's liability insurance and public liability insurance.

XXIII Patent Rights

The Contractor shall indemnify and save harmless the Owner and its officers, agents, and representatives from all claims for damages arising from the infringements, or alleged infringements, of any Letters Patent or patent rights covering any material, appliance, or device used in or upon the work or any part thereof.

XXIII Patent Rights (continued)

All royalties for patents or patent infringement claims, that might be involved in the construction or use of the work, shall be included in the Contract amount; and the Contractor shall satisfy all demands that may be made at any time for such and shall be liable for any damage or claims for patent infringements; and the Contractor shall, at his own expense, defend any and all suits or proceedings that may be instituted against the Owner for infringement, or alleged infringement, of any patent or patents involved, or alleged to be involved, in the work; and in case of any award for damages, the said Contractor shall pay such award.

XXIV Defense of Suits

The Contractor shall indemnify and hold harmless the Owner and its consultants, agents

and employees from and against all claims, damages, losses, and expenses, including, but not limited to, attorney fees, ("indemnification expense") arising out of or resulting from the performance of the work or arising out of or resulting from the Contract Documents, including, without limitation, all indemnification expense regarding personal injury or death and/or damage to real or personal property or motor vehicles.

In claims against any person or entity indemnified under this section by an employee or the Contractor, a Subcontractor, anyone directly or indirectly employed by them or anyone for whose acts they may be liable, the indemnification obligation under this Section shall not be limited by a limitation on amount or type of damages, compensation or benefits payable by or for the Contractor or a Subcontractor under worker's or workmen's compensation acts, disability benefit acts or other employee benefit acts.

XXV Claims for Labor and Materials

The Contractor shall indemnify and save harmless the Owner from all claims expenses and for judgements regarding labor done or materials furnished under this Contract, or any alterations or modifications thereof, including without limitation, reasonable Attorney's fees. Contractor shall furnish the Owner with a Mechanic's Lien Waiver from all persons who have done work, or furnished materials under this Contract. In case such waiver is not furnished, an amount necessary or sufficient, within the discretion of the Owner, to meet the claims of the persons aforesaid, shall be retained, as herein specified, from the money due the Contractor under this Contract until the liabilities aforesaid shall be fully discharged or satisfactorily secured.

XXVI Completion of Work by Owner

If the work to be done under this Contract shall be abandoned by the Contractor; or if this Contract shall be assigned, or the work sublet by him, otherwise than as herein specified; or if at any time the Owner shall be of the opinion that the performance of the Contract is unnecessarily or unreasonably delayed; or if the Contractor is willfully violating any of the conditions or covenants of this Contract, or of the Specifications, or is executing the same in bad faith or not in accordance with the terms thereof; or if the work be not fully completed within the time named in this Contract for its completion, or within the time to which the completion of the Contract may be extended by the Owner, the Owner may notify the Contractor to discontinue all work, or any part thereof under his Contract, by a written notice to be served upon the Contractor as herein provided.

The Contractor shall, within five (5) days of the service of said written notice, discontinue the work, or such part thereof, and the Owner shall thereupon have the power to contract for the completion of the Contract, in the manner prescribed by law; or to place such and so many persons as it may be deemed advisable, by contract or otherwise, to work, and complete the work herein described, or such part thereof; or to take possession of and use any of the materials, plant, tools, equipment, supplies, and property of every kind provided by the Contractor for the purpose of his work; and to procure other materials and equipment for the completion of the same; and to charge the expense of said labor, materials and equipment to the Contractor.

The expense so charged shall be deducted and paid by the Owner out of such moneys as may be due, or may at any time thereafter grow due to the Contractor under and by virtue of this Contract, or any part thereof; and in case such expense shall exceed the amount which would have

XXVI Completion of Work by Owner (continued)

been payable under the Contract, if the same had been completed by the Contractor, the Contractor or his surety shall pay the amount of such excess to the Owner within five (5) days of written demand therefore; and in case such expense shall be less than the amount which would have been payable under this Contract, if the same had been completed by the Contractor, the owner shall pay such difference to the Contractor within five (5) days of written demand.

XXVII Partial and Final Estimates

On, or about, the last day of the month, the Borough of Naugatuck Inspector shall make an approximate estimate of the value of the work done and of the materials incorporated into the work.

The Owner will pay the Contractor, within 30 days of receipt of an estimate, ninety-five percent (95%) of the total estimated value of the work done, as estimated by the Borough of Naugatuck Inspector less previous payments. Partial payments will not be made whenever the amounts of the estimate or estimates of work done since the last previous estimate are less than \$2,000.00.

The Borough of Naugatuck Inspector shall, as soon as practicable after the completion of work, make a final certificate of the entire amount of the work done under this Contract, and the value thereof, and the Owner shall, within thirty (30) days after such final estimate is approved, pay the entire sum so found to be due hereunder, after deducting there from all previous payments and also all percentages and deductions to be retained under any of the provisions of this Contract.

Before payment of each estimate, the Contractor shall provide the Owner with a mechanic's lien waiver from the Contractor and all persons who have done work or furnished materials under this Contract.

XXVIII Extra Work

The Contractor shall and will do any and all work and furnish any and all materials not herein provided for which, in the opinion of the Borough of Naugatuck Inspector, may be found necessary or advisable for the proper completion of the work or the purposes thereof, or any modifications or alternations thereto.

All extra work and materials shall be ordered in writing by the Borough of Naugatuck Inspector, and in no case will any work or materials in excess of the amount shown in the Plans and Specifications be paid for unless so ordered. Additionally, if the extra work requires additional cost, a purchase order must be issued prior to work commencing. No claim for delay shall be made as a result of this process. No voucher, claim or charge against the Borough shall be paid, nor is the Borough liable for any voucher, claim or charge unless a purchase order is issued. The Contractor further agrees that he shall accept, as full compensation for such extra work and materials, the unit price bid, in the case of Items covered by unit prices in the Proposal, and no more; and for such Items as are not covered by a unit price, he shall accept as full compensation:

1. an agreed on lump sum price, or
2. the reasonable cost, as determined by the Borough of Naugatuck Inspector, of all necessary labor, including insurance and payroll taxes, equipment rental, and materials, plus fifteen percent (15%) which covers supervision, the use of tools and plant, and other overhead expenses and profit.

The equipment rental charge shall be at prevailing rates usually paid locally but shall in no case exceed the amount prorated on the basis of the monthly equipment rental rates compiled by the Associated Equipment Distributors.

When extra work is performed by an approved subcontractor, the Contractor shall be entitled to five percent (5%) of the direct cost of the subcontractor's work to cover his overhead expenses and profit.

The Contractor agrees to prosecute such extra work with all reasonable diligence and to employ thereon competent men. The Contractor shall give the Borough of Naugatuck Inspector access to all accounts, bills, payrolls, and vouchers relating to extra work not covered by unit

prices, and he agrees that he shall have no claim for compensation for such extra work in the case of items not covered by unit prices, unless a statement in writing of the actual cost of the same, fully itemized as to labor and materials, is presented to the Borough of Naugatuck Inspector before the fifteenth (15th) day of the month following that during which each specific order was complied with by him.

XXIX Payment

The Owner, in consideration of the faithful performance by the Contractor of all and singular his covenants, promises, and agreements contained herein, agrees to pay the Contractor for the full completion by him of the work embraced in this Contract, in the manner and within the time herein specified and limited, and to the satisfaction and approval of the Borough of Naugatuck Inspector, the prices stipulated in the said Proposal hereto attached, such payment to be made at the times and in the manner and upon the conditions herein expressly provided. The Owner also agrees to pay in addition such amounts as may be agreed upon for modifications and for extra work.

XXX Guarantee

The Contractor guarantees that the work done under this Contract and the materials furnished by him and used in the construction of the same are free from defects or flaws. The guarantee is for a term of one (1) year from, and after, the date upon which the final estimate of the Borough of Naugatuck Inspector is formally approved by the Owner. It is hereby agreed and understood that this guarantee shall not include making any repairs made necessary by any cause or causes other than defective materials furnished by, or defective work done by, the Contractor.

XXXI Repairs for One (1) Year

The said party of the second part further agrees that if, at any time during the period of one (1) year from the date of the final estimate of the work herein contracted for, any part of the work done under this Contract shall be deemed by the Borough of Naugatuck Inspector to require repairing under the aforesaid Contractor's guarantee, then the said Owner shall notify the said Contractor to make the repairs so required at no expense to the Owner.

Such replacements, or repairs, shall be undertaken by the Contractor within twenty-four (24) hours after service of notice. If the Contractor unnecessarily delays or fails to make the ordered replacements or repairs within the time specified, or if any replacements or repairs are of such nature as not to allow for the time delay incident to the service of a notice, then the Owner will have the right to make such replacements or repairs, and the expenses thereof shall be paid by the Contractor.

XXXII Rate of Progress and Time of Completion

The Contractor shall commence work within ten (10) calendar days of the date of the Notice to Proceed. The rate of progress shall be such that the whole work shall be performed and the grounds cleared up in accordance with the Contract and Specifications within thirty (30) calendar days unless extensions of time shall be made for the reasons, and in the manner, stated under Article XXXIII, "Extension of Time".

The above calendar days includes time for the Contractor to obtain approval of a Erosion and Sediment Control Plan, as applicable.

XXXIII Extension of Time

The Contractor expressly covenants and agrees that, in undertaking to complete the work within the time mentioned, he has taken into consideration, and made allowance for, all of the ordinary delays and hindrances incidental to such work, whether growing out of delays in securing materials or workmen or otherwise. Should the Contractor, however, be substantially

delayed in the prosecution and completion of the work by any changes, additions, or omissions therein ordered in writing by the Borough of Naugatuck Inspector, or by fire, lightning, earthquake, tornado, cyclone, riot, insurrection, or war, or by the abandonment of the work by the workman engaged therein through no fault of the Contractor, or by the discharge of all or any material number of workmen in consequence of difficulties arising between the Contractor and such workmen, or by the neglect, delay, or default of any other contractor of the Owner, then the Contractor may, within five (5) days after the occurrence of the delay for which he claims allowance, notify the Borough of Naugatuck Inspector thereof in writing, and thereupon, and not otherwise, the Contractor shall be allowed such additional time for the completion of the work as the Borough of Naugatuck Inspector, in his discretion, shall award in writing, and his decision shall be final and conclusive upon the parties.

XXXIV Damages for Failure to Complete on Time

The Contractor shall pay to the Owner for each and every calendar day (including Saturdays, Sundays, and holidays) that he shall be in default in completing the entire work in the time stipulated in Article XXXII, or within the extension of time he may be granted as provided in Article XXXIII, the sum of Two Hundred Dollars (\$200.00) per day. This sum is hereby agreed upon not as a penalty but as liquidated damages which Owner will suffer by reason of such default, time being of the essence of the Contract and a material consideration thereof. The Owner shall have the right to deduct the amount of any such damages from any monies due the Contractor under this Contract.

XXXV No Waiver of Rights

No certificate given or payment made under this Contract, except the final certificate or final payment, shall be evidence of the performance of the Contract either wholly or in part, and no payment shall be construed to be an acceptance of defective work or improper materials. No act of the Owner or of the Borough of Naugatuck Inspector, or of any representatives of either of them in inspecting the work, nor any extension of time for the completion of the work, shall be regarded or taken as an acceptance of such work, or any part thereof, or materials used therein or thereof, either wholly or in part; but such acceptance shall be evidenced only by the final certificate of the Borough of Naugatuck Inspector.

Before any final certification shall be allowed, the Contractor shall be required, and he hereby agrees, to sign and attest on said certificate a statement that he accepts the same in full payment and settlement of all claims on account of work done and material furnished under this Contract, and furthermore, that all claims for materials provided or labor performed have been paid and satisfied in full. No waiver of any breach of this Contract by the Owner or anyone acting for it, or on its behalf, shall be held as a waiver of any other or subsequent breach thereof.

XXXVI Mandatory Negotiation

Contractor and the Owner agree that they will attempt to negotiate in good faith any dispute of any nature arising under this contract. The parties shall negotiate in good faith at not less than two negotiation sessions prior to seeking any resolution of any dispute under the provisions of arbitration paragraph of this contract. Each party shall have the right to legal representation at any such negotiation session.

XXXVII Arbitration

Any dispute or question arising under the provisions of this contract which has not been resolved under the mandatory negotiation paragraph of this contract shall be determined by arbitration. Arbitration proceedings shall occur at a neutral location in Waterbury, Connecticut, and shall be conducted in accordance with the rules then applicable of the American Arbitration Association. Arbitration shall proceed before a pane of one arbitrator to be selected by American Arbitration Association. The decision of the Arbitrator shall be final and may be entered in any court having jurisdiction thereof. Each party shall pay one-half of all costs and expenses of such

arbitration.

XXXVIII Owner's Right to Use

The Owner reserves the right to use or occupy any portion of the work considered by the Borough of Naugatuck Inspector as ready for use or occupancy. Such use or occupancy shall not be held, in any way, as final acceptance of the work or any portion thereof, or as a waiver of any portion of this Contract.

XXXIX Verification of Data

The quantities of work to be done and the materials to be furnished under this Contract, as given in the accompanying "Information for Bidders" and on the Proposal form, are approximate estimates for the purpose of comparing bids on a uniform basis. Neither the Owner nor the Borough of Naugatuck Inspector are to be held responsible for the data or information given relative to said quantities or that given on the Plans relative to existing conditions. The Contractor has judged for himself as to such quantities and as to other circumstances affecting the cost of the performance of this Contract, and he shall not at any time assert that there was any misunderstanding in regard to the character or amount of work to be done and materials and labor to be furnished.

XXXX Contractor's Wage Certification Form

If applicable the Contractor or his authorized agent will be required to sign the Contractor's Wage Certification Form at the time of Contract execution.

XXXXI Verbal Statements Not Binding

It is understood and agreed that the written terms and provisions of this Agreement shall supersede all prior verbal statements of the Borough of Naugatuck Inspector or other representatives of the Owner, and such statements shall not be effective or be construed as entering into or forming a part of, or altering in anyway whatsoever, the written Agreement.

XXXXII Final Estimate Constitutes Release

It is agreed that acceptance by the Contractor of the last payment made, under the provisions of Article XXVII, shall operate as and shall be a release to the Owner, and every agent thereof, from all claims and liability to Contractor for anything done or furnished for, or relating to, the work or for any act or neglect of the Owner or of any agent thereof, except any claim against the Owner for the remainder, if any, of the amounts kept or retained by the Owner as percentages or deductions.

No payment, however, final or otherwise, shall operate to release the Contractor or his sureties from any obligations under this Contract.

XXXXIII Delays or Termination by Governmental Authorities

Notwithstanding any other provision(s) of this contract, the parties agree that in the event of a stop work order from the State Department of Transportation, Department of Environmental Protection, or any other State or Federal agency, no additional compensation will be made by Owner to Contractor for delays, inconvenience or damage sustained by Contractor due to such order, including, without limitation, damages for loss of use of equipment or idle equipment. Similarly, in the event of a termination of the project by the State DOT, DEP or any other State or Federal agency, no additional compensation will be made by Owner to Contractor for the termination, or for any delay, inconvenience or damage sustained by Contractor due to such termination, including, without limitation, damages for loss of use of equipment or idle equipment. In the event of such termination, the Borough of Naugatuck Inspector shall prepare a final certificate for the entire amount of work done up to the effective date of termination. The

provisions of Sections XXX (Guarantee) and XXXI (Repair) shall apply to all work completed as of the effective date of any stop Work order, as if the effective date was the date upon which the final estimate of the Borough of Naugatuck Inspector is formally approved by the Borough.

XXXXIV Validity of Agreement

The provision of this Agreement shall be binding upon the Parties and their respective successor or assigns.

IN WITNESS WHEREOF, the said parties hereto have caused this instrument to be signed by their respective duly constituted officers, attested, and sealed pursuant to proper resolutions.

Signed and sealed
in the presence of

Borough of Naugatuck
Mayor

(Duly Authorized)
Contractor

CERTIFICATE AS TO CORPORATE PRINCIPAL

I, _____ certify that I am the _____ of the Corporation named as Contractor in the within bond; that _____, who signed the said bond on behalf of the Contractor was then _____ of said corporation; that I know his signature, and his signature thereto is genuine; and that said bond was duly signed, sealed, and attested to for and in behalf of said corporation by authority of this governing body.

(Corporate
Seal)

Title

SECTION F

PERFORMANCE BOND

PERFORMANCE BOND

KNOW ALL MEN BY THESE PRESENTS: that

(Name of Contractor)

(Address of Contractor)

a _____, hereinafter called Principal and
(Corporation, Partnership, or Individual)

(Name of Surety)

(Address of Surety)

hereinafter called Surety, are held and firmly bound unto

(Name of Owner)

(Address of Owner)

hereinafter called OWNER, in the penal sum of _____ Dollars,
\$(_____) in lawful money of the United States, for the payment of which sum well and truly to be made, we bind ourselves, successors, and assigns, jointly and severally, firmly by these presents.

THE CONDITION OF THIS OBLIGATION is such that whereas, the Principal entered into a certain contract with the OWNER, dated the ____ day of _____, 20__, a copy of which is hereto attached and made a part hereof for the construction of:

NOW, THEREFORE, if the Principal shall well, truly and faithfully perform its duties, all the undertakings, covenants, terms, conditions, and agreements of said contract during the original term thereof, an any extensions thereof which may be granted by the OWNER, with or without notice to the Surety and during the one year guaranty period, and if he shall satisfy all claims and demands incurred under such contract, and shall fully indemnify and save harmless the OWNER from all costs and damages which may suffer by reason of failure to do so, and shall reimburse and repay the OWNER all outlay and expense which the OWNER may incur in making good any default, then this obligation shall be void; otherwise to remain in full force and effect.

PROVIDED, FURTHER, that the said surety, for value received hereby stipulates and agrees that no change, extension of time, alteration or addition to the terms of the contract or to WORK to be performed thereunder or the SPECIFICATIONS accompanying the same shall in anyway affect its obligation on this BOND, and it does hereby waive notice of any such change, extension of time, alteration or addition to the terms of the contract or to the WORK or to the SPECIFICATIONS.

PROVIDED, FURTHER, that no final settlement between the OWNER and the CONTRACTOR shall abridge the right of any beneficiary hereunder, whose claim may be unsatisfied.

IN WITNESS WHEREOF, this instrument is executed in _____ counterparts each one of Which shall be deemed an original, this the _____ day of _____, 200__.

ATTEST:

_____	By _____(s)
(Principal) Secretary	Principal
(SEAL)	
_____	_____
(Witness as to Principal)	(Address)
_____	_____
(Address)	
_____	_____
	Surety

ATTEST:

(Surety) Secretary	
(SEAL)	
_____	By _____
Witness as to Surety	Attorney-in-Fact
_____	_____
(Address)	(Address)
_____	_____

NOTES: If CONTRACTOR is Partnership, all partners should execute BOND.

IMPORTANT: Surety companies executing BONDS must appear on the Treasury Department's most current list (Circular 570 as amended) and be authorized to transact business in the state where the PROJECT is located.

SECTION G
PAYMENT BOND

PAYMENT BOND

KNOW ALL MEN BY THESE PRESENTS: that

(Name of Contractor)

(Address of Contractor)

a _____, hereinafter called Principal and
(Corporation, Partnership, or Individual)

(Name of Surety)

(Address of Surety)

hereinafter called Surety, are held and firmly bound unto

(Name of Owner)

(Address of Owner)

hereinafter called OWNER, in the penal sum of

_____ Dollars, \$(_____)

in lawful money of the United States, for the payment of which sum well and truly to be made, we bind ourselves, successors, and assigns, jointly and severally, firmly by these presents.

THE CONDITION OF THIS OBLIGATION is such that whereas, the Principal entered into a certain contract with the OWNER, dated the _____ day of _____, 20__ , a copy of which is hereto attached and made a part hereof for the construction of:

NOW, THEREFORE, if the Principal shall well, truly and faithfully perform its duties, all the undertakings, covenants, terms, conditions, and agreements of said contract during the original term thereof, an any extensions thereof which may be granted by the OWNER, with or without notice to the Surety and during the one year guaranty period, and if he shall satisfy all claims and demands incurred under such contract, and shall fully indemnify and save harmless the OWNER from all costs and damages which may suffer by reason of failure to do so, and shall reimburse and repay the OWNER all outlay and expense which the OWNER may incur in making good any default, then this obligation shall be void; otherwise to remain in full force and effect.

PROVIDED, FURTHER, that the said surety, for value received hereby stipulates and agrees that no change, extension of time, alteration or addition to the terms of the contract or to WORK to be performed thereunder or the SPECIFICATIONS accompanying the same shall in anyway affect its obligation on this BOND, and it does hereby waive notice of any such change, extension of time, alteration or addition to the terms of the contract or to the WORK or to the SPECIFICATIONS.

PROVIDED, FURTHER, that no final settlement between the OWNER and the CONTRACTOR shall abridge the right of any beneficiary hereunder, whose claim may be unsatisfied.

IN WITNESS WHEREOF, this instrument is executed in _____ counterparts each one of which shall be deemed an original, this the _____ day of _____, 20__.

ATTEST:

(Principal) Secretary

By _____(s)
Principal

(SEAL)

(Witness as to Principal)

(Address)

(Address)

Surety

ATTEST:

(Surety) Secretary

(SEAL)

Witness as to Surety

By _____
Attorney-in-Fact

(Address)

(Address)

IMPORTANT: Surety companies executing BONDS must appear on the Treasury Department's most current list (Circular 570 as amended) and be authorized to transact business in the state where the PROJECT is located.

SECTION H

Specifications

SECTION 4.06 - BITUMINOUS CONCRETE

Section 4.06 is being deleted in its entirety and replaced with the following:

4.06.01—Description

4.06.02—Materials

4.06.03—Construction Methods

4.06.04—Method of Measurement

4.06.05—Basis of Payment

4.06.01—Description: Work under this section shall include the production, delivery and placement of a non-segregated, smooth and dense bituminous concrete mixture brought to proper grade and cross section. This section shall also include the method and construction of longitudinal joints. The Contractor shall furnish ConnDOT with a Quality Control Plan as described in Article 4.06.03.

The terms listed below as used in this specification are defined as:

Bituminous Concrete: A concrete material that uses a bituminous material (typically asphalt) as the binding agent and stone and sand as the principal aggregate components. Bituminous concrete may also contain any of a number of additives engineered to modify specific properties and/or behavior of the concrete material. For the purposes of this Specification, references to bituminous concrete apply to all of its sub-categories, for instance those defined on the basis of production and placement temperatures, such as hot-mix asphalt (HMA) or warm-mix asphalt (WMA), those categories derived from the mix-design procedure used, such as “Marshall” mixes or “Superpave” mixes, or those defined on the basis of composition, such as polymer-modified asphalt (PMA).

Course: A lift or multiple lifts comprised of the same bituminous concrete mixture placed as part of the pavement structure.

Density Lot: All material placed in a single lift and as defined in Article 4.06.03.

Disintegration: Wearing away or fragmentation of the pavement. Disintegration will be evident in the following forms: Polishing, weathering-oxidizing, scaling, spalling, raveling, potholes or loss of material.

Dispute Resolution: A procedure used to resolve conflicts resulting from discrepancies between the Engineer and the Contractor’s density results that may affect payment.

Hot Mix Asphalt (HMA): A bituminous concrete mixture typically produced at 325°F.

Lift: An application of a bituminous concrete mixture placed and compacted to a specified thickness in a single paver pass.

Marshall: A bituminous concrete mix design used in mixtures designated as “Bituminous Concrete Class ()”.

Polymer Modified Asphalt (PMA): A bituminous concrete mixture containing a polymer modified asphalt binder in accordance with contract specifications.

Production Lot: All material placed during a continuous daily paving operation.

Quality Assurance (QA): All those planned and systematic actions necessary to provide confidence that a product or facility will perform as designed.

Quality Control (QC): The sum total of activities performed by the vendor (Producer, Manufacturer, and Contractor) to ensure that a product meets contract specification requirements.

Superpave: A bituminous concrete mix design used in mixtures designated as “S*” Where “S” indicates Superpave and * indicates the sieve related to the nominal maximum aggregate size of the mix.

Segregation: A non-uniform distribution of a bituminous concrete mixture in terms of volumetrics, gradation or temperature.

Warm Mix Asphalt (WMA): A bituminous concrete mixture that can be produced and placed at reduced temperatures than HMA using a qualified additive or technology.

4.06.02—Materials: All materials shall conform to the requirements of Section M.04.

1. Materials Supply: The bituminous concrete mixture must be from one source of supply and originate from one Plant unless authorized by the Engineer. Bituminous Concrete plant QC plan requirements are defined in Section M.04.

2. Recycle Option: The Contractor has the option of recycling reclaimed asphalt pavement (RAP) or Crushed Recycled Container Glass (CRCG) in bituminous concrete mixtures in accordance with Section M.04. CRCG shall not be used in the final lift of the surface course.

4.06.03—Construction Methods:

1. Material Documentation: All vendors producing bituminous concrete must have their truck-weighing scales, storage scales, and mixing plant automated to provide a detailed ticket.

Delivery tickets must include the following information:

- a. State of Connecticut printed on ticket.
- b. Name of producer, identification of plant, and specific storage bin (silo) if used.
- c. Date and time of day.
- d. Mixture Designation If RAP is used, the plant printouts shall include RAP dry weight, percentage and daily moisture content. If WMA technology is used, the technology and

the additive rate or the water injection rate must be noted on the ticket. Class 3 mixtures for machine-placed curbing must state "curb mix only".

- e. Net weight of mixture loaded into truck (When RAP is used, RAP moisture shall be excluded from mixture net weight).
- f. Gross weight (Either equal to the net weight plus the tare weight or the loaded scale weight).
- g. Tare weight of truck – Daily scale weight.
- h. Project number, purchase order number, name of Contractor (if Contractor other than Producer).
- i. Truck number for specific identification of truck.
- j. Individual aggregate, RAP, and virgin asphalt high/target/low weights shall be printed on batch plant tickets (For drum plants and silo loadings, the plant printouts shall be printed out at 5 minute intervals maintained by the vendor for a period of three years after the completion of the project).
- k. For every mixture designation the running daily total delivered and sequential load number.

The net weight of mixture loaded into the truck must be equal to the cumulative measured weight of its components.

The Contractor must notify the Engineer immediately if, during the production day, there is a malfunction of the weighing or recording system in the automated plant or truck-weighing scales.

Manually written tickets containing all required information will be allowed for one hour, but for no longer, provided that each load is weighed on State-approved scales. At the Engineer's sole discretion, trucks may be approved to leave the plant if a State inspector is present to monitor weighing. If such a malfunction is not fixed within forty-eight hours, mixture will not be approved to leave the plant until the system is fixed to the Engineer's satisfaction. No damages will be considered should the State be unable to provide an inspector at the plant.

The State reserves the right to have an inspector present to monitor batching and /or weighing operations.

2. Transportation of Mixture: Trucks with loads of bituminous concrete being delivered to State projects must not exceed the statutory or permitted load limits referred to as gross vehicle weight (GVW). The Contractor shall furnish a list of all vehicles and allowable weights transporting mixture.

The State reserves the right to check the gross and tare weight of any delivery truck. A variation of 0.4 percent or less in the gross or tare weight shown on the delivery ticket and the certified scale weight shall be considered evidence that the weight shown on the delivery ticket is correct.

If the gross or tare weight varies from that shown on the delivery ticket by more than 0.4 percent, the Engineer will recalculate the net weight. The Contractor shall take action to correct discrepancy to the satisfaction of the Engineer.

If a truck delivers mixture to the project and the ticket indicates that the truck is overweight, the load will not be rejected but a "Measured Weight Adjustment" will be taken in accordance with Article 4.06.04.

The mixture shall be transported from the mixing plant in trucks that have previously been cleaned of all foreign material and that have no gaps through which mixture might inadvertently escape. The Contractor shall take care in loading trucks uniformly so that segregation is minimized. Loaded trucks shall be tightly covered with waterproof covers acceptable to the Engineer. Mesh covers are prohibited. The front and rear of the cover must be fastened to minimize air infiltration. The Contractor shall assure that all trucks are in conformance with this specification. Trucks found not to be in conformance shall not be allowed to be loaded until re-inspected to the satisfaction of the Engineer.

Truck body coating and cleaning agents must not have a deleterious effect on the transported mixture. The use of solvents or fuel oil, in any concentration, is strictly prohibited for the coating of the inside of truck bodies. When acceptable coating or agents are applied, truck bodies shall be raised immediately prior to loading to remove any excess agent in an environmentally acceptable manner.

3. Paving Equipment: The Contractor shall have the necessary paving and compaction equipment at the project site to perform the work. All equipment shall be in good working order and any equipment that is worn, defective or inadequate for performance of the work shall be repaired or replaced by the Contractor to the satisfaction of the Engineer. During the paving operation, the use of solvents or fuel oil, in any concentration, is strictly prohibited as a release agent or cleaner on any paving equipment (i.e., rollers, pavers, transfer devices, etc.).

Refueling of equipment is prohibited in any location on the paving project where fuel might come in contact with bituminous concrete mixtures already placed or to be placed. Solvents for use in cleaning mechanical equipment or hand tools shall be stored clear of areas paved or to be paved. Before any such equipment and tools are cleaned, they shall be moved off the paved or to be paved area; and they shall not be returned for use until after they have been allowed to dry.

Pavers: Each paver shall have a receiving hopper with sufficient capacity to provide for a uniform spreading operation and a distribution system that places the mix uniformly, without segregation. The paver shall be equipped with and use a vibratory screed system with heaters or burners. The screed system shall be capable of producing a finished surface of the required evenness and texture without tearing, shoving, or gouging the mixture. Pavers with extendible screed units as part of the system shall have auger extensions and tunnel extenders as necessary. Automatic screed controls for grade and slope shall be used at all times unless otherwise authorized by the Engineer. The controls shall automatically adjust the screed to compensate for irregularities in the preceding course or existing base. The controls shall maintain the proper transverse slope and be readily adjustable, and shall operate from a fixed or moving reference such as a grade wire or floating beam.

Rollers: All rollers shall be self-propelled and designed for compaction of bituminous concrete. Roller types shall include steel-wheeled, pneumatic or a combination thereof and may be capable of operating in a static or dynamic mode. Rollers that operate in a dynamic mode shall have drums that use a vibratory or oscillatory system or combination of. The vibratory system achieves compaction through vertical amplitude forces. Rollers with this system shall be equipped with indicators that provide the operator with amplitude, frequency and speed

settings/readouts to measure the impacts per foot during the compaction process. The oscillatory system achieves compaction through horizontal shear forces. Rollers with this system shall be equipped with frequency indicators. Rollers can operate in the dynamic mode using the oscillatory system on concrete structures such as bridges and catch basins if at the lowest frequency setting.

Pneumatic tire rollers shall be self-propelled and equipped with wide-tread compaction tires capable of exerting an average contact pressure from 60 to 90 pounds per square inch uniformly over the surface, adjusting ballast and tire inflation pressure as required. The Contractor shall furnish evidence regarding tire size; pressure and loading to confirm that the proper contact pressure is being developed and that the loading and contact pressure are uniform for all wheels.

Lighting: For paving operations, which will be performed during hours of darkness, the paving equipment shall be equipped with lighting fixtures as described below, or with approved lighting fixtures of equivalent light output characteristics. A sufficient number of spare lamps shall be available on site as replacements in the event of failures. The Contractor shall provide brackets and hardware for mounting light fixtures and generators to suit the configuration of the rollers and pavers. Mounting brackets and hardware shall provide for secure connection of the fixtures, minimize vibration, and allow for adjustable positioning and aiming of the light fixtures. Lighting shall be aimed to maximize the illumination on each task and minimize glare to passing traffic. The Contractor shall provide generators on rollers and pavers of the type, size, and wattage, to adequately furnish 120 V AC of electric power to operate the specified lighting equipment. A sufficient amount of fuel shall be available on site. There shall be switches to control the lights. Wiring shall be weatherproof and installed to all applicable codes. The minimum lighting requirements are found in tables 4.06-1 and 4.06-2:

Table 4.06-1: Paver Lighting

Fixture	Quantity	Remarks
Type A	3	Mount over screed area
Type B (narrow) or Type C (spot)	2	Aim to auger and guideline
Type B (wide) or Type C (flood)	2	Aim 25 feet behind paving machine

Table 4.06-2: Roller Lighting

Fixture*	Quantity	Remarks
Type B (wide)	2	Aim 50 feet in front of and behind roller
Type B (narrow)	2	Aim 100 feet in front of and behind roller
OR		
Type C (flood)	2	Aim 50 feet in front of and behind roller
Type C (spot)	2	Aim 100 feet in front of and behind roller

*All fixtures shall be mounted above the roller.

Type A: Fluorescent fixture shall be heavy-duty industrial type. It shall be enclosed and sealed to keep out dirt and dampness. It shall be UL listed as suitable for wet locations. The fixture shall contain two 4-foot long lamps - Type "F48T12CWHO". The integral ballast shall be a high power factor, cold weather ballast, and 120 volts for 800 MA HO

lamps. The housing shall be aluminum, and the lens shall be acrylic with the lens frame secured to the housing by hinging latches. The fixture shall be horizontal surface mounting, and be made for continuous row installation.

Type B: The floodlight fixture shall be heavy-duty cast aluminum housing, full swivel and tilt mounting, tempered-glass lens, sealed door, reflector to provide a wide distribution or narrow distribution as required, mogul lamp socket for 250 watt Metal Halide lamp, 120 volt integral ballast, and be UL listed as suitable for wet locations.

Type C: The power beam holder shall have ribbed die cast aluminum housing and a clear tempered-glass lens to enclose the fixture. There shall be an arm fully adjustable for aiming, with a male-threaded mount with serrated teeth and lock nuts. There shall be a 120-volt heatproof socket with extended fixture wiring for an "Extended Mogul End Prong" lamp base. The fixture shall have gaskets, and shall be UL listed as suitable for wet locations. The lamps shall be 1000-watt quartz PAR64, both Q1000PAR64MFL (flood) and Q1000PARNSP (spot) will be required.

Material Transfer Vehicle (MTV): A MTV shall be used when placing a bituminous concrete surface course as indicated in the contract documents. A surface course is defined as the total thickness of the same bituminous concrete mix that extends up to and includes the final wearing surface whether it is placed in a single or multiple lifts, and regardless of any time delays between lifts.

The MTV must be a self-propelled vehicle specifically designed for the purpose of delivering the bituminous concrete mixture from the delivery truck to the paver. The MTV must have the capability to remix the bituminous concrete mixture.

The use of a MTV will be subject to the requirements stated in Article 1.07.05- Load Restrictions. The Engineer may limit the use of the vehicle if it is determined that the use of the MTV may damage highway components, utilities, or bridges. The Contractor shall submit to the Engineer at time of pre-construction the following information:

- The make and model of the MTV to be used.
- The individual axle weights and axle spacing for each separate piece of paving equipment (haul vehicle, MTV and paver).
- A working drawing showing the axle spacing in combination with all three pieces of equipment that will comprise the paving echelon.

4. Seasonal Requirements: Paving, including placement of temporary pavements, shall be divided into two seasons, In-Season and Extended Season. In-Season paving shall occur from May 1 – October 14, and Extended Season shall occur from October 15- April 30. The following requirements shall apply unless otherwise authorized or directed by the Engineer:

- Bituminous concrete mixes shall not be placed when the air or subbase temperature is below 40°F regardless of the season.
- Should paving operations be scheduled during the Extended Season, the Contractor's Quality Control Plan for placement described in Section 9. "Contractor Quality Control Plan for Placement" shall include a separate section titled "Extended Season Paving" and address minimum delivered mix temperature, maximum paver speed, enhanced rolling

patterns and the method to balance mixture delivery and placement operations. Work covered by the section on Extended Season paving shall not commence until the Engineer's comments have been incorporated into the section and approved.

- Should placement of the final lift of bituminous concrete be scheduled during the Extended Season, the Contractor is required to submit this plan to the Engineer for review 30 days prior to the paving operation.

5. Superpave Test Section: The Engineer may require the Contractor to place a test section whenever the requirements of this specification or Section M.04 are not met.

The Contractor shall submit the quantity of mixture to be placed and the location of the test section for review and acceptance by the Engineer. The equipment used in the construction of a passing test section shall be used throughout production.

If a test section fails to meet specifications, the Contractor shall stop production, make necessary adjustments to the job mix formula, plant operations, or procedures for placement and compaction. The Contractor shall construct test sections, as allowed by the Engineer, until all the required specifications are met. All test sections shall also be subject to removal as set forth in Article 1.06.04.

6. Transitions for Roadway Surface: Transitions shall be formed at any point on the roadway where the pavement surface deviates, vertically, from the uniform longitudinal profile as specified on the plans. Whether formed by milling or by bituminous concrete mixture, all transition lengths shall conform to the criteria below unless otherwise specified.

Permanent Transitions: A permanent transition is defined as any transition that remains as a permanent part of the work. All permanent transitions, leading and trailing ends shall meet the following length requirements:

- a) Posted speed limit is greater than 35 MPH: 30 feet per inch of vertical change (thickness)
- b) Posted speed limit is 35 MPH or less: 15 feet per inch of vertical change (thickness).
- c) Bridge Overpass and underpass transition length will be 75 feet either
 - (1) Before and after the bridge expansion joint, or
 - (2) Before or after the parapet face of the overpass.

In areas where it is impractical to use the above described permanent transition lengths the use of a shorter permanent transition length may be permitted when approved by the Engineer.

Temporary Transitions: A temporary transition is defined as a transition that does not remain a permanent part of the work. All temporary transitions shall meet the following length requirements:

- a) Posted speed limit is greater than 35 MPH
 - (1) Leading Transitions = 15 feet per inch of vertical change (thickness)
 - (2) Trailing Transitions = 6 feet per inch of vertical change (thickness)
- b) Posted speed limit is 35 MPH or less
 - (1) Leading and Trailing = 4 feet per inch of vertical change (thickness)

Note: Any temporary transition to be in-place over the winter shutdown period, holidays, or during extended periods of inactivity (more than 7 calendar days) shall conform to the “Permanent Transition” requirements shown above.

7. Spreading and Finishing of Mixture: Prior to the placement of the bituminous concrete, the underlying base course shall be brought to the plan grade and cross section within the allowable tolerance. Immediately before placing the mixture, the area to be surfaced shall be cleaned by sweeping or by other means acceptable to the Engineer. The bituminous concrete mixture shall not be placed whenever the surface is wet or frozen. The Engineer will verify the mix temperature by means of a probe or infrared type of thermometer. A probe type thermometer, verified by the Department on an annual basis, must be used in order to reject a load of mixture based on temperatures outside the range stated in the placement QC plan.

Placement: The bituminous concrete mixture shall be placed and compacted to provide a smooth, dense surface with a uniform texture and no segregation at the specified thickness and dimensions indicated in the plans and specifications.

When unforeseen weather conditions prevent further placement of the mix, the Engineer is not obligated to accept or place the bituminous concrete mixture that is in transit from the plant.

In advance of paving, traffic control requirements shall be set up daily, maintained throughout placement, and shall not be removed until all associated work including density testing is completed.

The Contractor shall inspect the newly placed pavement for defects in the mixture or placement before rolling is started. Any deviation from standard crown or section shall be immediately remedied by placing additional mixture or removing surplus mixture. Such defects shall be corrected to the satisfaction of the Engineer.

Where it is impractical due to physical limitations to operate the paving equipment, the Engineer may permit the use of other methods or equipment. Where hand spreading is permitted, the mixture shall be placed by means of suitable shovels and other tools, and in a uniformly loose layer at a thickness that will result in a completed pavement meeting the designed grade and elevation.

Placement Tolerances: Each lift of bituminous concrete placed at a uniform specified thickness shall meet the following requirements for thickness and area. Any pavement exceeding these limits shall be subject to an adjustment or removal. Lift tolerances will not relieve the Contractor from meeting the final designed grade. Lifts of specified non-uniform thickness, i.e. wedge or shim course, shall not be subject to thickness and area adjustments.

- a) Thickness- Where the total thickness of the lift of mixture exceeds that shown on the plans beyond the tolerances shown in Table 4.06-3, the longitudinal limits of such variation including locations and intervals of the measurements will be documented by the Engineer for use in calculating an adjustment in accordance with Article 4.06.04.

TABLE 4.06-3 Thickness Tolerances

Mixture Designation	Lift Tolerance
Class 4 and S1	+/- 3/8 inch
Class 1, 2 and 12 and S0.25, S0.375, S0.5	+/- 1/4 inch

Where the thickness of the lift of mixture is less than that shown on the plans beyond the tolerances shown in Table 4.06-3, the Contractor, with the approval of the Engineer, shall take corrective action in accordance with this specification.

- b) Area- Where the width of the lift exceeds that shown on the plans by more than the specified thickness of each lift, the longitudinal limits of such variation including locations and intervals of the measurements will be documented by the Engineer for use in calculating the adjustment in Article 4.06.04.
- c) Delivered Weight of Mixture - When the delivery ticket shows that the truck exceeds the allowable gross weight for the vehicle type the quantity of tons representing the overweight amount will be documented by the Engineer for use in calculating an adjustment in accordance with Article 4.06.04.

Transverse Joints: All transverse joints shall be formed by saw-cutting a sufficient distance back from the previous run, existing bituminous concrete pavement or bituminous concrete driveways to expose the full thickness of the lift. A brush of tack coat shall be used on any cold joint immediately prior to additional bituminous concrete mixture being placed.

Tack Coat Application: A thin uniform coating of tack coat shall be applied to the pavement immediately before overlaying and be allowed sufficient time to break (set). All surfaces in contact with the bituminous concrete that have been in place longer than 3 calendar days shall have an application of tack coat. The tack coat shall be applied by a non-gravity pressurized spray system that results in uniform overlapping coverage at an application rate of 0.03 to 0.05 gallons per square yard for a non-milled surface and an application rate of 0.05 to 0.07 gallons per square yard for a milled surface. For areas where both milled and un-milled surfaces occur, the tack coat shall be an application rate of 0.03 to 0.05 gallons per square yard. The Engineer must approve the equipment and the method of measurement prior to use. The material for tack coat shall not be heated in excess of 160°F and shall not be further diluted.

Compaction: The Contractor shall compact the mixture to meet the density requirements as stated in Article 4.06.03 and eliminate all roller marks without displacement, shoving, cracking, or aggregate breakage.

The Contractor shall only operate rollers in the dynamic mode using the oscillatory system at the lowest frequency setting on concrete structures such as bridges and catch basins. The use of the vibratory system on concrete structures is prohibited. Rollers operating in the dynamic mode shall be shut off when reversing directions.

If the Engineer determines that the use of compaction equipment in the dynamic vibratory mode may damage highway components, utilities, or adjacent property, the Contractor shall provide

alternate compaction equipment. The Engineer may allow the Contractor to operate rollers in the dynamic mode using the oscillatory system at the lowest frequency setting.

These allowances will not relieve the Contractor from meeting pavement compaction requirements.

Surface Requirements: The pavement surface of any lift shall meet the following requirements for smoothness and uniformity. Any irregularity of the surface exceeding these requirements shall be corrected by the Contractor.

- a) Smoothness- Each lift of the surface course shall not vary more than $\frac{1}{4}$ inch from a Contractor-supplied 10 foot straightedge. For all other lifts of bituminous concrete, the tolerance shall be $\frac{3}{8}$ inch. Such tolerance will apply to all paved areas.
- b) Uniformity- The paved surface shall not exhibit segregation, rutting, cracking, disintegration, flushing or vary in composition as determined by the Engineer.

8. Longitudinal Joint Construction Methods: Unless noted on the plans or the contract documents or directed by the Engineer, the Contractor shall use Method I- Notched Wedge Joint (see figure 4.06-1) when constructing longitudinal joints where lift thicknesses are between $1\frac{1}{2}$ and 3 inches, except for S1 and Class 4 mixes. Method II Butt Joint (see figure 4.06-2) shall be used for lifts less than $1\frac{1}{2}$ inches or greater than 3 inches, and S1 and Class 4 mixes. During placement of multiple lifts of bituminous concrete, the longitudinal joint shall be constructed in such a manner that it is located at least 6 inches from the joint in the lift immediately below. The joint in the final lift shall be at the centerline or at lane lines. Each longitudinal joint shall maintain a consistent offset from the centerline of the roadway along its entire length.

Method I - Notched Wedge Joint:

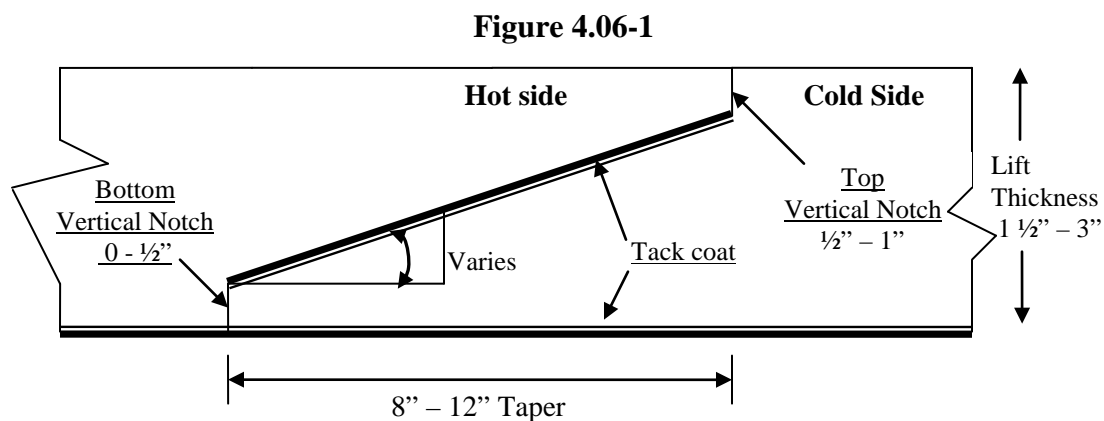

A notched wedge joint shall be constructed, as shown in the figure using a device that is capable of adjusting the top and bottom vertical notches independently and is attached to the paver screed.

The taper portion of the joint must be placed over the longitudinal joint in the lift immediately below. The top vertical notch must be located at the centerline or lane line in the final lift. The

requirement for paving full width “curb to curb” as described in Method II may be waived if addressed in the QC plan and approved by the Engineer.

The taper portion of the wedge joint shall be compacted and not be exposed to traffic for more than 5 calendar days.

The pavement surface under the wedge joint must have an application of tack coat material. Prior to placing the completing pass (hot side), an application of tack coat must be applied to the exposed surface of the tapered section; regardless of time elapsed between paver passes. The in-place time allowance described in Sub article 4.06.03-7 does not apply to joint construction.

Any exposed wedge joint must be located to allow for the free draining of water from the road surface.

The Engineer reserves the right to define the paving limits when using a wedge joint that will be exposed to traffic.

Method II - Butt Joint:

Figure 4.06-2

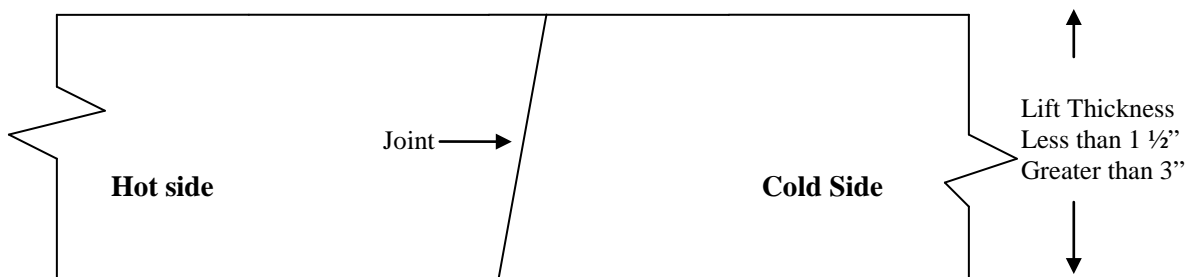

When adjoining passes are placed, the Contractor shall utilize equipment that creates a near vertical edge (refer to figure). The completing pass (hot side) shall have sufficient mixture so that the compacted thickness is not less than the previous pass (cold side). The end gate on the paver should be set so there is an overlap onto the cold side of the joint.

The Contractor shall not allow any butt joint to be incomplete at the end of a work shift unless otherwise allowed by the Engineer. When using this method, the Contractor is not allowed to

leave a vertical edge exposed at the end of a work shift and must complete paving of the roadway full width “curb to curb.”

Method III- Butt Joint with Hot Poured Rubberized Asphalt Treatment: When required by the contract or allowed by the Engineer, Method III (see figure 4.06-3) may be used.

Figure 4.06-3

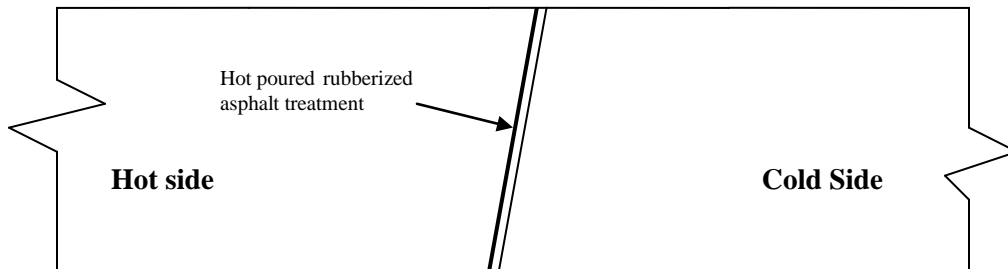

All of the requirements of Method II must be met with Method III. In addition, the longitudinal vertical edge must be treated with a joint seal material meeting the requirements of Section M.04 prior to placing a completing pass. The joint seal material shall be applied in accordance with the manufacturer’s recommendation so as to provide a uniform coverage and avoid excess bleeding onto the newly placed pavement.

9. Contractor Quality Control (QC) Requirements for Placement:

The Contractor shall be responsible for maintaining adequate quality control procedures throughout the placement operations. Therefore, the Contractor must ensure that the materials, mixture and work provided by Subcontractors, Suppliers and Producers also meet contract specification requirements.

Quality Control Plan: Prior to placement the Contractor shall submit a QCP to the Engineer for approval. The QCP shall be submitted at the pre-construction meeting or a minimum 30 days prior to any production or paving. The QCP shall be in the format provided by the Engineer (http://www.ct.gov/dot/lib/dot/documents/dconstruction/pat/2012_qcp_outline_hma_placement_112012.pdf). Work covered by the QCP shall not commence until the Engineer’s comments have been incorporated into the QCP and approved. The QCP shall detail every aspect of the placement process and if required, include a separate section on Extended Season paving as described in Section 4. “Seasonal Requirements”. Information provided shall include the organization and procedures which the Contractor shall use to control all project site activity. The QCP must address the actions, inspection, or sampling and testing necessary to keep the production and placement operations in control, to determine when an operation has gone out of control and to respond to correct the situation in a timely fashion. The QCP shall also include details on when and who will communicate with personnel at the bituminous concrete plant to determine when immediate changes to the production or placement processes are needed, and to implement the required changes.

In addition the QCP shall also include the name and qualifications of a Quality Control Manager (QCM). The QCM shall be responsible for the administration of the QCP, and any modifications that may become necessary. The QCM shall have the ability to direct all Contractor personnel on the project during paving operations. All Contractor sampling, inspection and test reports shall be reviewed and signed by the QCM prior to submittal to the Engineer.

Approval of the QCP will be based on the inclusion of all of the required information. Approval of the QCP does not relieve the Contractor of its responsibility to comply with the project specifications. The Contractor may modify the QCP as work progresses and must document the changes in writing prior to commencing the next paving operation. These changes include but are not limited to changes in quality control procedures or personnel. Placement may be suspended by the Engineer until the revisions to the QCP have been put into effect.

The Quality Control Plan shall also include the name and qualifications of any outside testing laboratory performing any QC functions on behalf of the Contractor.

Quality Control Inspection, Sampling and Testing: The Contractor shall perform all quality control sampling and testing, provide inspection, and exercise management control to ensure that bituminous concrete production and placement conforms to the requirements as outlined in its QCP during all phases of the work.

a) Control Charts: The Contractor shall develop and maintain density control charts and shall submit them to the Engineer. The control charts shall include the project number, test numbers, test parameter, applicable upper and lower specification limits, and test data. The control charts shall be used as part of the quality control system to document the placement process. The control chart(s) shall be updated each day of production, and a copy shall be submitted prior to the next day's production.

b) Records of Inspection and Testing: For each day of placement, the Contractor shall document all test results and inspections on forms approved by the Engineer. The document shall be certified by the Quality Control Manager or his representative that the information in the document is accurate, and that all work complies with the requirements of the contract.

The Contractor shall submit complete and accurate density sampling, testing and inspection documents to the Engineer within 48 hours. The documents shall be submitted in a manner acceptable to the Engineer.

The Contractor may obtain one (1) mat core and one (1) joint core per day for process control, provided this process is detailed in the QCP. The results of these process control cores shall not be used to dispute the Department determinations from the acceptance cores. The Contractor shall submit the location of each process control core to the Engineer for approval prior to taking the core. Additional cores may be obtained to correlate a density gauge used by the contractor for quality control as approved by the Engineer. The core holes shall be filled to the same requirements described in Sub article 4.06.03-10.

10. Density Testing of Bituminous Concrete Utilizing Core Samples: This procedure describes the frequency and the method the Contractor shall use to obtain pavement cores for

acceptance from the project. Coring shall be performed on each lift specified to a thickness of one and one-half (1 ½) inches or more. Each lift including the longitudinal joints shall be compacted to the degree specified in Tables 4.06-9 and 4.06-10. The density of each core shall be determined using the production lot's average maximum theoretical gravity established from the plant production testing. Bituminous concrete Class 4 and HMA S1 are excluded from the longitudinal joint density requirements.

The Contractor shall extract cores (4 or 6 inch diameter for S0.25, S0.375 and S0.5 mixes, 6 inch diameter for S1.0 mixtures -wet sawed) from sampling locations determined by the Engineer. The Engineer must witness the extraction and labeling of cores, as well as the filling of the core holes. The cores shall be labeled by the Contractor with the project number, lot number, and sub-lot number on the top surface of the core. When labeling the core lot number, include whether the core is from a mat lot or joint lot by using an “M” for a mat core and “J” for a joint core. For example, a core from the first sub-lot of the first mat lot shall be labeled with “Lot M1 – 1”. The first number refers to the lot and the second number refers to the sub-lot. Refer to Figure 4.06-4. The side of the cores shall be labeled with the core lot number and date placed. The project inspector shall fill out a MAT-109 containing the same information to accompany the cores. The Contractor shall deliver the cores and MAT-109 to the Department’s Central Testing Lab in a safe manner to ensure no damage occurs to the cores. The Contractor shall use a container approved by the Engineer. In general the container shall consist of an attached lid container made out of plastic capable of being locked shut and tamper proof. The Contractor shall use foam, bubble wrap, or another suitable material to prevent the cores from being damaged during transportation. Once the cores and MAT-109 are in the container the Engineer will secure the lid using a security seal. The security seal’s identification number must be documented on the MAT-109. The Central Lab will break the security seal and take possession of the cores upon receipt.

Figure 4.06-4

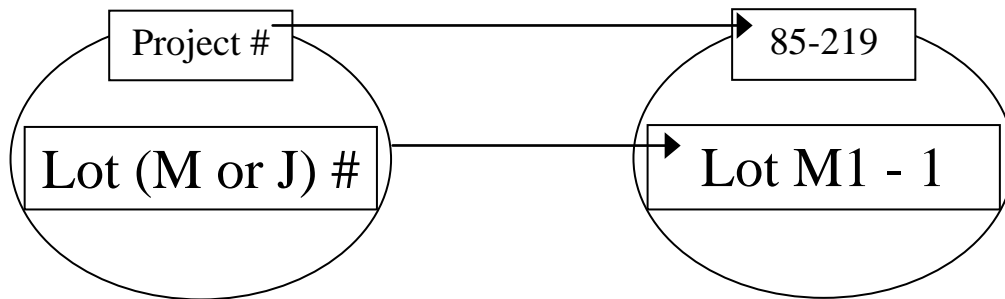

Frequency of sampling is in accordance with the following tables:

TABLE 4.06-4 - TESTING REQUIREMENT FOR BRIDGE DENSITY LOT

Length of Each Structure (Feet)	MAT – No. of Cores	JOINT - No. of cores
≤ 500'	See Table 4.06-5(A or B)	See Table 4.06-5(A or B)
501' – 1500'	3	3
1501' – 2500'	4	4
2501' and greater	5	5

All material placed on structures less than or equal to 500 feet in length shall be included as part of a standard lot as follows:

**TABLE 4.06-5A – TESTING REQUIREMENT FOR DENSITY LOTS
≥ 500 TONS**

Lot Type	No. of Mat Cores		No. of Joint Cores		Target Lot Size (Tons)
Lot Without Bridge ⁽¹⁾	4		4		2000
Lot With Bridge(s) ⁽¹⁾⁽²⁾	4 plus	1 per structure (≤ 300')	4 plus	1 per structure (≤ 300')	2000
		2 per structure (301' – 500')		2 per structure (301' – 500')	

**TABLE 4.06-5B – TESTING REQUIREMENT FOR DENSITY LOTS
< 500 TONS**

Lot Type	No. of Mat Cores	No. of Joint Cores	Lot Size (Tons)
Lot Without Bridge ⁽¹⁾	3	3	1 per lift
Lot With Bridge(s) ⁽¹⁾⁽²⁾	3	3	1 per lift

Note (1): The number of “Required Paver Passes for Full Width” shall be used to determine the sub-lot sizes within the lot. The number of paver passes for full width is determined by the contractor.

Note (2): If a non-bridge mat or joint core location randomly falls on a structure, the core is to be obtained on the structure in addition to the core(s) required on the structure.

A density lot will be complete when the full designed paving width of the established lot length has been completed and shall include all longitudinal joints that exist between the curb lines regardless of date(s) paved. Quantity of material placed on structures less than or equal to 500 feet long is inclusive of the standard lot. Prior to paving, the total length of the project to be paved shall be split up into lots that contain approximately 2000 tons each. Areas such as highway ramps may be combined to create one lot. In general, combined areas should be set up to target a 2000 ton lot size. One adjustment will apply for each lot. The tons shall be determined using the yield calculation in Article 4.06.04. The last lot shall be the difference between the total payable tons for the project and the sum of the previous lots.

After the compaction process has been completed, the material shall be allowed to cool sufficiently to allow the cutting and removal of the core without damage. The Contractor shall core to a depth that allows extraction so that the uppermost layer being tested for density will not be affected.

A mat core shall not be taken any closer than one foot from the edge of a paver pass. If a random number locates a core less than one foot from any edge, locate the core so that the sample is one foot from the edge.

Joint cores must be taken so that the center of the core is 5 inches from the visible joint on the hot mat side. Refer to figure 4.06-5.

Figure 4.06-5

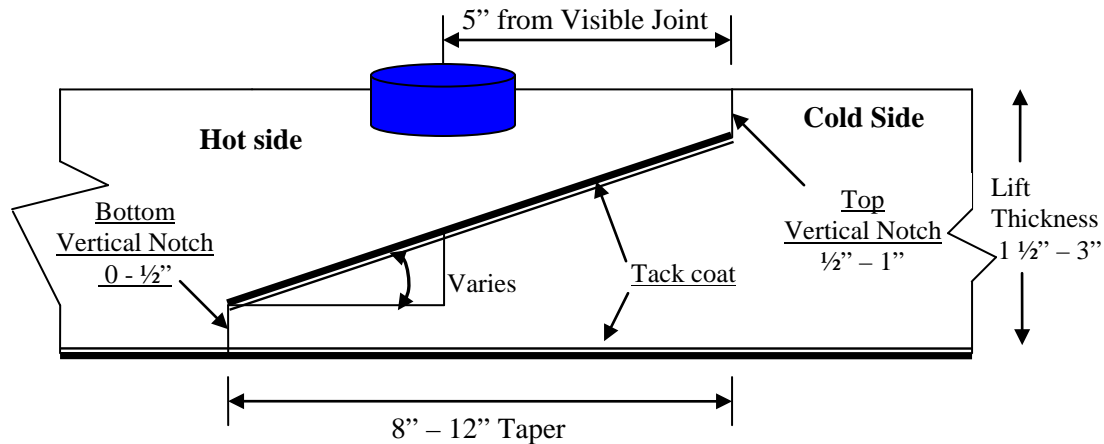

Cores may be obtained daily or weekly. All cores must be cut within 5 calendar days of placement. Any core that is damaged or obviously defective while being obtained will be replaced with a new core from a location within 2 feet measured in a longitudinal direction.

Core holes shall be filled immediately upon core extraction. Prior to being filled, the hole shall be prepared by removing any free water and applying tack coat using a brush or other means to uniformly cover the cut surface. The core hole shall be filled with a mixture containing the same nominal maximum aggregate size and compacted with a hand compactor or other mechanical means to the maximum compaction possible. The bituminous concrete mixture shall be compacted to 1/8 inch above the finished pavement prior to opening the roadway to traffic.

11. Acceptance Inspection, Sampling and Testing: Inspection, sampling, and testing to be used by the Engineer shall be performed at the minimum frequency specified in Section M.04 and stated herein.

Sampling for acceptance shall be established using ASTM D 3665, or a statistically based procedure of random sampling approved by the Engineer.

Plant Material Acceptance: The Contractor shall provide the required acceptance sampling, testing and inspection during all phases of the work in accordance with Section M.04. The Department will perform verification testing on the Contractor's acceptance test results. Should binder content or air void results exceed the specified tolerances in the Department's current QA Program for Materials, Acceptance and Assurance Testing Policies and Procedures, the Department will investigate to determine an assignable cause. Contractor's test results for a subject lot or sub lot may be replaced with verification's result for the purpose of assessing adjustments. The verification procedure is included in the Department's current QA Program for Materials.

Density Acceptance: The Engineer will perform all acceptance testing on the cores in accordance with AASHTO T 331(M).

12. Density Dispute Resolution Process: The Contractor and Engineer will work in partnership to avoid potential conflicts and to resolve any differences that may arise during quality control or acceptance testing for density. Both parties will review their sampling and testing procedures

and results and share their findings. If the Contractor disputes the Engineer's test results, the Contractor must submit in writing a request to initiate the Dispute Resolution Process within 10 calendar days of the notification of the test results. No request for dispute resolution will be allowed unless the Contractor provides quality control results within the timeframe described in Sub article 4.06.03-9 supporting its position. Should the dispute not be resolved through evaluation of existing testing data or procedures, the Engineer may authorize the Contractor to obtain a new set of core samples per disputed lot. The core samples must be extracted no later than 30 calendar days from the date of Engineer's authorization. The number and type (mat, joint, or structure) of the cores taken for dispute resolution must reflect the number and type of the cores taken for acceptance. The location of each core shall be 36" from the original acceptance core location forward along a line parallel to the baseline that results in the same type (mat, joint, or structure) of core. All such core samples shall be extracted and filled using the procedure outlined in Article 4.06.03. The results from the dispute resolution cores shall be added to the results from the acceptance cores and averaged for determining the final in-place density value.

13. Corrective Work Procedures: Any portion of the completed pavement that does not meet the requirements of the specification shall be corrected at the expense of the Contractor. Any corrective courses placed as the final wearing surface shall not be less than 1½ inches in thickness after compaction.

If pavement placed by the Contractor does not meet the specifications, and the Engineer requires its replacement or correction, the Contractor shall:

Propose a corrective procedure to the Engineer for review and approval prior to any corrective work commencing. The proposal shall include:

Limits of pavement to be replaced or corrected, indicating stationing or other landmarks that are readily distinguishable.

Proposed work schedule.

Construction method and sequence of operations.

Methods of maintenance and protection of traffic.

Material sources.

Names and telephone numbers of supervising personnel.

Perform all corrective work in accordance with the Contract and the approved corrective procedure.

14. Protection of the Work: The Contractor shall protect all sections of the newly finished pavement from damage that may occur as a result of the Contractor's operations for the duration of the Project. Prior to the Engineer's authorization to open the pavement to traffic, the Contractor is responsible to protect the pavement from damage.

15. Cut Bituminous Concrete Pavement: Work under this item shall consist of making a straight-line cut in the bituminous concrete pavement to the lines delineated on the plans or as directed by the Engineer. The cut shall provide a straight, clean, vertical face with no cracking, tearing or breakage along the cut edge.

4.06.04—Method of Measurement:

1. Bituminous Concrete Class () or HMA S* or PMA S*: The quantity of bituminous concrete measured for payment will be determined by the documented net weight in tons accepted by the Engineer in accordance with this specification and Section M.04.

2. Adjustments: Adjustments may be applied to bituminous concrete quantities and will be measured for payment using the following formulas:

Yield Factor for Adjustment Calculation = 0.0575 Tons/SY/inch

$$\text{Actual Area} = [(\text{Measured Length (ft)}) \times (\text{Avg. of width measurements (ft)})]$$

Actual Thickness (t) = Total tons delivered / [Actual Area (SY) x 0.0575 Tons/SY/inch]

Area: If the average width exceeds the allowable tolerance, an adjustment will be made using the following formula. The tolerance for width is equal to the specified thickness (in.) of the lift being placed.

$$\text{Tons Adjusted for Area (T}_A) = [(L \times W_{adj})/9] \times (t) \times 0.0575 \text{ Tons/SY/inch} = (-) \text{ Tons}$$

Where: L = Length (ft)

(t) = Actual thickness (inches)

$W_{adj} = (\text{Designed width (ft)} + \text{tolerance} / 12) - \text{Measured Width}$

Thickness: If the actual thickness is less than the allowable tolerance, the Contractor shall submit a repair procedure to the Engineer for approval. If the actual thickness exceeds the allowable tolerance, an adjustment will be made using the following formula:

$$\text{Tons Adjusted for Thickness (T}_T) = A \times t_{adj} \times 0.0575 = (-) \text{ Tons}$$

Where: A = Area = {[L x (Designed width + tolerance (lift thickness)/12)] / 9}

$t_{adj} = \text{Adjusted thickness} = [(\text{Dt} + \text{tolerance}) - \text{Actual thickness}]$

Dt = Designed thickness (inches)

Weight: If the quantity of bituminous concrete representing the mixture delivered to the project is in excess of the allowable gross vehicle weight (GVW) for each vehicle, an adjustment will be made using the following formula:

$$\text{Tons Adjusted for Weight (T}_W) = \text{GVW} - \text{DGW} = (-) \text{ Tons}$$

Where: DGW = Delivered gross weight as shown on the delivery ticket or measured on a certified scale.

Mixture Adjustment: If the quantity of bituminous concrete representing the produced mixture exceeds one or more of the production tolerances for Marshall (Table 4.06-6) or Superpave mix designs (Table 4.06-7 and 4.06-8), an adjustment will be made using the following formulas.

The Department's Division of Material Testing will calculate the daily adjustment values for T_{MD} and T_{SD} .

Marshall Design- The tolerances shown in Table 4.06-6 for gradation and binder content will be used to determine whether a mixture adjustment will apply. If the mixture does not meet the requirements of Section M.04, an adjustment will be computed using the following formula:

$$\text{Tons Adjusted for Marshall Design (T}_{MD}) = M \times 0.10$$

Where: M= Tons of bituminous concrete mixture exceeding the tolerances in Table 4.06-5.

**TABLE 4.06-6
TOLERANCES FOR CONSECUTIVE TESTS (MARSHALL)**

Classes	Criteria	% Tolerances (+/-)
-	Binder	0.4
1, 2, 4, 5, 5A & 5B	#200	2.0
1, 2, 4	#50	4
1, 2, 5, 5A & 5B	#30	5
1, 2, 4, 5, 5A & 5B	#8	6
1, 2, 4, 5, 5A & 5B	#4	7
1, 2, 4, 5, 5A & 5B	3/8 & 1/2 inch	8

Superpave Design- The adjustment values in Table 4.06-7 and 4.06-8 shall be calculated for each sub lot based on the Air Void and Liquid Binder Content test results for that sub lot. The total adjustment for each day's production (lot) will be computed using tables and the following formulas:

$$\text{Tons Adjusted for Superpave Design (T}_{SD}) = [(\text{AdjAV}_t + \text{AdjPB}_t) / 100] \times \text{Tons}$$

$$\text{Percent Adjustment for Air Voids} = \text{AdjAV}_t = [\text{AdjAV}_1 + \text{AdjAV}_2 + \text{AdjAV}_i + \dots + \text{AdjAV}_n] / n$$

Where: AdjAV_t = Total percent air void adjustment value for the lot

AdjAV_i = Adjustment value from Table 4.06-7 resulting from each sub lot or the average of the adjustment values resulting from multiple tests within a sub lot, as approved by the Engineer.

n = number of sub lots based on Table M.04.03-1

**TABLE 4.06-7
ADJUSTMENT VALUES FOR AIR VOIDS (SUPERPAVE)**

Adjustment Value (AdjAV_i) (%)	S0.25, S0.375, S0.5, S1 Air Voids (AV)
+2.5	3.8 - 4.2
+3.125*(AV-3)	3.0 - 3.7
-3.125*(AV-5)	4.3 - 5.0
20*(AV-3)	2.3 - 2.9
-20*(AV-5)	5.1 - 5.7
-20.0	≤ 2.2 or ≥ 5.8

$$\text{Percent Adjustment for Liquid Binder} = \text{AdjPB}_t = [(\text{AdjPB}_1 + \text{AdjPB}_2 + \text{AdjPB}_i + \dots + \text{AdjPB}_n)] / n$$

Where: AdjPB_t = Total percent liquid binder adjustment value for the lot
 AdjPB_i = Adjustment value from Table 4.06-7 resulting from each sub lot
 n = number of binder tests in a production lot

TABLE 4.06-8

Adjustment Value (AdjAV_i) (%)	S0.25, S0.375, S0.5, S1 Pb (refer to Table M.04.03-5)
0.0	Equal to or above the min. liquid content
- 10.0	Below the min. liquid content

Density Adjustment: The quantity of bituminous concrete measured for payment for a specified lift of pavement 1½ inches or greater may be adjusted for density. Separate density adjustments will be made for each lot and will not be combined to establish one density adjustment. If either the Mat or Joint adjustment value is “remove and replace”, the density lot shall be removed and replaced (curb to curb).

$$\text{Tons Adjusted for Density (T}_D) = [\{ (PA_M \times .50) + (PA_J \times .50) \} / 100] \times \text{Density Lot Tons}$$

Where: T_D = Total tons adjusted for density for each lot
 PA_M = Mat density percent adjustment from Table 4.06-9
 PA_J = Joint density percent adjustment from Table 4.06-10

**TABLE 4.06-9
ADJUSTMENT VALUES FOR PAVEMENT MAT DENSITY**

Average Core Result Percent Mat Density	Percent Adjustment (Bridge and Non-Bridge) (1,2)
97.1 - 100	-1.667*(ACRPD-98.5)
94.5 – 97.0	+2.5
93.5 – 94.4	+2.5*(ACRPD-93.5)
92.0 – 93.4	0
90.0 – 91.9	-5*(92-ACRPD)
88.0 – 89.9	-10*(91-ACRPD)
87.0 – 87.9	-30
86.9 or less	Remove and Replace (curb to curb)

**TABLE 4.06-10
ADJUSTMENT VALUES FOR PAVEMENT JOINT DENSITY**

Average Core Result Percent Joint Density	Percent Adjustment (Bridge and Non-Bridge) (1,2)
97.1 – 100	-1.667*(ACRPD-98.5)
93.5 – 97.0	+2.5
92.0 – 93.4	+1.667*(ACRPD-92)
91.0 – 91.9	0
89.0 – 90.9	-7.5*(91-ACRPD)
88.0 – 88.9	-15*(90-ACRPD)
87.0 – 87.9	-30
86.9 or less	Remove and Replace (curb to curb)

(1) ACRPD = Average Core Result Percent Density

(2) All Percent Adjustments to be rounded to the second decimal place. For example, 1.667 is to be rounded to 1.67.

3. Transitions for Roadway Surface: The installation of permanent transitions shall be measured under the appropriate item used in the formation of the transition.

The quantity of material used for the installation of temporary transitions shall be measured for payment under the appropriate item used in the formation of the transition. The installation and removal of a bond breaker, and the removal and disposal of any temporary transition formed by milling or with bituminous concrete pavement is not measured for payment.

4. Cut Bituminous Concrete Pavement: The quantity of bituminous concrete pavement cut will be measured in accordance with Article 2.02.04.

5. Material for Tack Coat: The quantity of tack coat will be measured for payment by the number of gallons furnished and applied on the Project and approved by the Engineer. No tack coat material shall be included that is placed in excess of the tolerance described in Article 4.06.03.

Method of Measurement:

a. Container Method- Material furnished in a container will be measured to the nearest ½ gallon. The volume will be determined by either measuring the volume in the original container by a method approved by the Engineer or using a separate graduated container capable of measuring the volume to the nearest ½ gallon. The container in which the material is furnished must include the description of material, including lot number or batch number and manufacturer or product source.

b. Truck Method- The Engineer will establish a weight per gallon of the bituminous material based on the specific gravity at 60°F for the material furnished. The number of gallons furnished will be determined by weighing the material on scales furnished by and at the expense of the Contractor.

6. Material Transfer Vehicle (MTV) - The furnishing and use of a MTV will be measured separately for payment based on the actual number of surface course tons delivered to a paver using the MTV.

4.06.05—Basis of Payment:

1. Bituminous Concrete Class (), HMA S* or PMA S*: The furnishing and placing of bituminous concrete will be paid for at the Contract unit price per ton for "Bituminous Concrete, Class ()" or "HMA S*" or "PMA S*".

- All costs associated with providing illumination of the work area are included in the general cost of the work.

- All costs associated with constructing longitudinal joints are included in the general cost of the work.

- All costs associated with obtaining cores for core correlation and dispute resolution are included in the general cost of the work.

2. Bituminous Concrete Adjustment Costs: The adjustment will be calculated using the formulas shown below if all of the measured adjustments in Article 4.06.04 do not equal zero. A payment will be made for a positive adjustment. A deduction from monies due the Contractor will be made for a negative adjustment.

$$\text{Production Lot: } [T_T + T_A + T_W + (T_{MD} \text{ or } T_{SD})] \times \text{Unit Price} = \text{Est. (P)}$$

$$\text{Density Lot: } T_D \times \text{Unit Price} = \text{Est. (D)}$$

Where: Unit Price = Contract unit price per ton per type of mixture

T_* = Total tons of each adjustment calculated in Article 4.06.04

Est. () = Pay Unit represented in dollars representing incentive or disincentive.

The estimated cost figure if included in the bid proposal or estimate is not to be altered in any manner by the bidder. If the bidder should alter the amount shown, the altered figure will be disregarded and the original cost figure will be used to determine the amount of the bid for the Contract.

3. Transitions for Roadway Surface: The installation of permanent transitions shall be paid under the appropriate item used in the formation of the transition. The quantity of material used for the installation of temporary transitions shall be paid under the appropriate pay item used in the formation of the transition. The installation and removal of a bond breaker, and the removal and disposal of any temporary transition formed by milling or with bituminous concrete pavement is included in the general cost of the work.

4. The cutting of bituminous concrete pavement will be paid in accordance with Article 2.02.05.

5. Material for tack coat will be paid for at the Contract unit price per gallon for "Material for Tack Coat".

6. The Material Transfer Vehicle (MTV) will be paid at the Contract unit price per ton for a "Material Transfer Vehicle".

<u>Pay Item*</u>	<u>Pay Unit*</u>
Bituminous Concrete, Class ()	ton
HMA S*	ton
PMA S*	ton
Bituminous Concrete Adjustment Cost	est.
Material for Tack Coat	gal.
Material Transfer Vehicle	ton

*For contracts administered by the State of Connecticut, Department of Administrative Services, the pay items and pay units are as shown in contract award price schedule.

END OF SECTION

SECTION M.04 - BITUMINOUS CONCRETE

Section M.04 is being deleted in its entirety and replaced with the following:

M.04.01—Bituminous Concrete Materials and Facilities

M.04.02—Mix Design and Job Mix Formula (JMF)

M.04.03—Production Requirements

M.04.01—Bituminous Concrete Materials and Facilities: Each source of material, and facility or plant used to produce and test bituminous concrete must be qualified on an annual basis by the Engineer. Test Procedures and Specifications referenced herein are in accordance with the latest AASHTO and ASTM Standard Test Procedures and Specifications. Such references when noted with an (M) have been modified by the Engineer and are detailed in Table M.04.03-6.

The Contractor shall submit to the Engineer all sources of coarse aggregate, fine aggregate, mineral filler, PG binder, and if applicable any additives such as but not limited to anti-strip, warm mix, and polymer modifiers. The Contractor shall submit a Material Safety Data Sheet (MSDS) for each grade of binder, and additive to be used on the Project. The Contractor shall not change any material sources without prior approval of the Engineer.

An adequate quantity of each size aggregate, mineral filler, bitumen, and additives, shall be maintained at the bituminous concrete plant site at all times while the plant is in operation to ensure that the plant can consistently produce bituminous concrete mixtures that meet the job mix formula (JMF) as specified in Article M.04.02. The quantity of such material shall be reviewed by the Engineer on an individual plant basis and is dependent upon the plant's daily production capacity. A total quantity of any material on site that amounts to less than one day's production capacity may be cause for the job mix formula to be rejected.

1. Coarse Aggregate:

Requirements: The coarse aggregate shall consist of clean, hard, tough, durable fragments of crushed stone or crushed gravel of uniform quality. Aggregates from multiple sources of supply must not be mixed or stored in the same stockpile.

Basis of Approval: The request for approval of the source of supply shall include a washed sieve analysis in accordance with AASHTO T 27. The G_{sa} , G_{sb} , and Pw_a shall be determined in accordance with AASHTO T 85. The coarse aggregate must not contain more than 1% crusher dust, sand, soft disintegrated pieces, mud, dirt, organic and other injurious materials. When tested for abrasion using AASHTO T 96, the aggregate loss must not exceed 40%. When tested for soundness using AASHTO T 104 with a magnesium sulfate solution, the coarse aggregate must not have a loss exceeding 10% at the end of 5 cycles.

For all bituminous mixtures, materials shall also meet the coarse aggregate angularity criteria as specified in Tables M.04.02-2 thru M.04.02-4 for blended aggregates retained on the #4 sieve when tested according to ASTM D 5821. The amount of aggregate particles of the coarse aggregate blend retained on the #4 sieve that are flat or elongated shall be determined in

accordance with ASTM D 4791 and shall not exceed 10% by weight when tested to a 3:1 ratio, as shown in Tables M.04.02-2 thru M.04.02-4.

2. Fine Aggregate:

Requirements: The fine aggregate from each source quarry/pit deposit shall consist of clean, hard, tough, rough-surfaced and angular grains of natural sand; manufactured sand prepared from washed stone screenings; stone screenings, slag or gravel; or combinations thereof, after mechanical screening or manufactured by a process approved by the Engineer. The Contractor is prohibited from mixing two or more sources of fine aggregate on the ground for the purpose of feeding into a plant.

All fine aggregate shall meet the listed criteria shown in items #1 thru #7 of Table M.04.01-1. Table M.04.01-1 indicates the quality tests and criteria required for all fine aggregate sources. Individually approved sources of supply shall not be mixed or stored in the same stockpile. The fine aggregates must be free from injurious amounts of clay, loam, and other deleterious materials.

For Superpave mixtures, in addition to the above requirements, the fine aggregate angularity shall be determined by testing the materials passing the #8 sieve in accordance with AASHTO T 304, Method A. Qualification shall be based on the criteria listed in Tables M.04.02-2 thru M.04.02-4. The fine aggregate shall also be tested for clay content as a percentage contained in materials finer than the #8 sieve in accordance with AASHTO T 176.

Table M.04.01-1: Fine Aggregate Criteria by Pit/Quarry Source

Item	Title	AASHTO Protocol(s)	Criteria
1	Grading	T 27 & T 11	100% Passing 3/8 inch 95% Passing the #4 min.
2	Absorption	T 84	3% maximum
3	Plasticity limits	T 90	0 or not detectable
4	L.A. Wear	T 96	50% maximum(fine agg. particle size # 8 and above)
5	Soundness by Magnesium Sulfate	T 104	20% maximum @ 5 cycles
6	Clay Lumps and Friable Particles	T 112	3% maximum
7	Deleterious Material	As determined by the Engineer	Organic or inorganic calcite, hematite, shale, clay or clay lumps, friable materials, coal-lignite, shells, loam, mica, clinkers, or organic matter (wood, etc). -Shall not contain more than 3% by mass of any individual listed constituent and not more than 5% by mass in total of all listed constituents.
8	Petrographic Analysis	ASTM C 295	Terms defined in Section M.04.01-2c.

Basis of Approval: A Quality Control Plan for Fine Aggregate (QCPFA) provided by the Contractor shall be submitted for review and approval for each new source documenting how conformance to Items 1 through 7 as shown in Table M.04.01-1 is monitored. The QCPFA must be resubmitted any time the process, location or manner of how the fine aggregate (FA) is manufactured changes, or as requested by the Engineer. The QCPFA must include the locations

and manufacturing processing methods. The QCPFA for any source may be suspended by the Engineer due to the production of inconsistent mixtures.

The Contractor shall submit all test results to the Engineer for review. The Contractor shall also include a washed sieve analysis in accordance with AASHTO T 27/T 11. Any fine aggregate component or final combined product shall have 100% passing the 3/8 inch sieve and a minimum of 95% passing the # 4. The G_{sa} , G_{sb} , and P_{w_a} shall be determined in accordance with AASHTO T 84.

The Contractor will be notified by the Engineer if any qualified source of supply fails any portion of Table M.04.01-1. One retest will be allowed for the Contractor to make corrections and/or changes to the process. If, upon retest, the material does not meet the requirements of items 1-7, additional testing will be required in accordance with item 8.

The Contractor may provide a Petrographic analysis of the material performed by a third party acceptable to the Engineer at its' own expense. The Contractor shall submit the results of the analysis with recommended changes to the manufacturing process to the Engineer. The Contractor shall submit fine aggregate samples for testing by the Engineer after the recommended changes have been made.

The Contractor may request the use of such fine aggregate on select project(s) for certain applications of bituminous concrete pavement. Such material will be monitored for a period no less than 48 months, at no cost to the State. Terms of any evaluation and suitable application will be determined by the Engineer.

3. Mineral Filler:

Requirements: Mineral filler shall consist of finely divided mineral matter such as rock dust, including limestone dust, slag dust, hydrated lime, hydraulic cement, or other accepted mineral matter. At the time of use it shall be freely flowing and devoid of agglomerations. Mineral filler shall be introduced and controlled at all times during production in a manner acceptable to the Engineer.

Basis of Approval: The request for approval of the source of supply shall include the location, manufacturing process, handling and storage methods for the material. Mineral filler shall conform to the requirements of AASHTO M-17

Liquid Bituminous Materials:

General:

i Liquid PG binders shall be uniformly mixed and blended and be free of contaminants such as fuel oils and other solvents. Binders shall be properly heated and stored to prevent damage or separation.

The blending at mixing plants of PG binder from different suppliers is strictly prohibited. Contractors who blend PG binders will be classified as a supplier and will be required to certify the binder in accordance with AASHTO R-26(M). The binder shall meet the requirements of AASHTO M-320(M) and AASHTO R-29(M). The Contractor shall submit a Certified Test

Report and bill of lading representing each delivery in accordance with AASHTO R-26(M). The Certified Test Report must also indicate the binder specific gravity at 77°F; rotational viscosity at 275°F and 329°F and the mixing and compaction viscosity-temperature chart for each shipment.

The Contractor shall submit the name(s) of personnel responsible for receipt, inspection, and record keeping of PG binder materials. Contractor plant personnel shall document specific storage tank(s) where binder will be transferred and stored until used, and provide binder samples to the Engineer upon request. The person(s) shall assure that each shipment (tanker truck) is accompanied by a statement certifying that the transport vehicle was inspected before loading and was found acceptable for the material shipped and that the binder will be free of contamination from any residual material, along with two (2) copies of the bill of lading.

Basis of Approval: The request for approval of the source of supply shall list the location where the material will be manufactured, and the handling and storage methods, along with necessary certification in accordance with AASHTO R-26(M). Only suppliers/refineries that have an approved “Quality Control Plan for Performance Graded Binders” formatted in accordance with AASHTO R-26(M) will be allowed to supply PG binders to Department projects.

Neat Performance Grade (PG) Binder:

PG binder shall be classified by the supplier as a “Neat” binder for each lot and be so labeled on each bill of lading. Neat PG binders shall be free from modification with: fillers, extenders, reinforcing agents, adhesion promoters, thermoplastic polymers, acid modification and other additives, and shall indicate such information on each bill of lading and certified test report.

The asphalt binder shall be Performance Grade PG 64-22.

Modified Performance Grade (PG) Binder

Unless otherwise noted, the asphalt binder shall be Performance Grade PG 76-22 asphalt modified with a Styrene-Butadiene-Styrene (SBS) polymer. The polymer modifier shall be added at either the refinery or terminal and delivered to the bituminous concrete production facility as homogenous blend. The stability of the modified binder shall be verified in accordance with ASTM D7173 using the Dynamic Shear Rheometer (DSR). The DSR $G^*/\sin(\delta)$ results from the top and bottom sections of the ASTM D7173 test shall not differ by more than 10%. The results of ASTM D7173 shall be included on the Certified Test Report. The binder shall meet the requirements of AASHTO M-320(M) and AASHTO R-29(M).

Warm Mix Additive or Technology:

The warm mix additive or technology must be listed on the NEAUPG Qualified Warm Mix Asphalt (WMA) Technologies List at the time of bid, which may be accessed online at http://www.neaupg.uconn.edu/wma_info.html.

The warm mix additive shall be blended with the asphalt binder in accordance with the manufacturer’s recommendations.

The blended binder shall meet the requirements of AASHTO M-320(M) and AASHTO R-29(M) for the specified binder grade. The Contractor shall submit a Certified Test Report showing the results of the testing demonstrating the binder grade. In addition, it must include the grade of the virgin binder, the brand name of the warm mix additive, the manufacturer's suggested rate for the WMA additive, the water injection rate (when applicable) and the WMA Technology manufacturer's recommended mixing and compaction temperature ranges.

Cut-backs (medium cure type):

Requirements: The liquid petroleum materials shall be produced by fluxing an asphalt base with appropriate petroleum distillates to produce the grade specified.

Basis of Approval: The request for approval of the source of supply shall be submitted at least seven days prior to its use listing the location where the materials will be produced, and manufacturing, processing, handling and storage methods. The Contractor shall submit a Certified Test Report in accordance with Section 1.06 and a Material Safety Data Sheet (MSDS) for the grade to be used on the Project. The liquid asphalt shall be MC-250 conforming to AASHTO M-82.

Emulsions

Requirements: The emulsified asphalt shall be homogeneous and not be used if exposed to freezing temperatures.

Basis of Approval: The request for approval of the source of supply must include the location where the materials will be produced, and manufacturing, processing, handling and storage methods.

Emulsified asphalts shall conform to the requirements of AASHTO M-140. Materials used for tack coat shall not be diluted and meet grade RS-1. When ambient temperatures are 80°F and rising, grade SS-1 or SS-1h may be substituted if accepted by the Engineer. Each shipment shall be accompanied with a Certified Test Report listing Saybolt viscosity, residue by evaporation, penetration of residue, and weight per gallon.

Cationic emulsified asphalt shall conform to the requirements of AASHTO M-208(M). Materials used for tack coat shall not be diluted and meet grade CRS-1. The settlement and demulsibility test will not be performed unless deemed necessary by the Engineer. When ambient temperatures are 80°F and rising, grade CSS-1 or CSS-1h may be substituted if accepted by the Engineer. Each shipment shall be accompanied with a Certified Test Report listing Saybolt viscosity, residue by evaporation, penetration of residue, and weight per gallon.

Reclaimed Asphalt Pavement (RAP):

Requirements: RAP shall consist of asphalt pavement constructed with asphalt and aggregate reclaimed by cold milling or other removal techniques approved by the Engineer. For bituminous concrete mixtures containing RAP, the Contractor shall submit a JMF in accordance with Article M.04.02 to the Engineer for review.

Basis of Approval: The RAP material will be accepted on the basis of one of the following criteria:

When the source of all RAP material is from pavements previously constructed on Department projects, the Contractor shall provide a materials certificate listing the detailed locations and lengths of those pavements and that the RAP is only from those locations listed.

When the RAP material source or quality is not known, the Contractor shall test the material and provide the following information along with a request for approval to the Engineer at least 30 calendar days prior to the start of the paving operation. The request shall include a material certificate stating that the RAP consists of aggregates that meet the specification requirements of sub articles M.04.01-1 through 3 and that the binder in the RAP is substantially free of solvents, tars and other contaminants. The Contractor is prohibited from using unapproved material on Department projects and shall take necessary action to prevent contamination of approved RAP stockpiles. Stockpiles of unapproved material shall remain separate from all other RAP materials at all times. The request for approval shall include the following:

A 50-pound sample of the RAP to be incorporated into the recycled mixture.

A 25-pound sample of the extracted aggregate from the RAP.

A statement that RAP material has been crushed to 100% passing the 1/2 inch sieve and remains free from contaminants such as joint compound, wood, plastic, and metals.

6. Crushed Recycled Container Glass (CRCG):

Requirements: The Contractor may propose to use clean and environmentally-acceptable CRCG in an amount not greater than 5% by weight of total aggregate.

Basis of Approval: The Contractor shall submit to the Engineer a request to use CRCG. The request shall state that the CRCG contains no more than 1% by weight of contaminants such as paper, plastic and metal and conform to the following gradation:

CRCG Grading Requirements	
<u>Sieve Size</u>	<u>Percent Passing</u>
3/8-inch	100
No. 4	35-100
No. 200	0.0-10.0

7. Joint Seal Material:

Requirements: Joint seal material shall be a hot-poured rubber compound intended for use in sealing joints and cracks in bituminous concrete pavements. Joint seal material must meet the requirements of AASHTO M-324 – Type 2.

8. Plant Requirements:

Mixing Plant and Machinery:

The mixing plant used in the preparation of the bituminous concrete shall comply with AASHTO

M-156(M)/ASTM D 995 for a Batch Plant or a Drum Dryer Mixer Plant, and be approved by the Engineer.

Storage Silos:

For all mixes, the Contractor may use silos for short-term storage of Superpave mixtures with prior notification and approval of the Engineer. A silo must have heated cones and an unheated silo cylinder if it does not contain a separate internal heating system. Prior approval must be obtained for storage times greater than those indicated. When multiple silos are filled, the Contractor shall discharge one silo at a time. Simultaneous discharge of multiple silos is not permitted.

<u>Type of silo cylinder</u>	<u>Maximum storage time for all classes (hr)</u>	
	HMA	WMA/PMA
Open Surge	4	Mfg Recommendations
Unheated – Non-insulated	8	Mfg Recommendations
Unheated – Insulated	18	Mfg Recommendations
Heated – No inert gas	TBD by the Engineer	

Documentation System: The mixing plant documentation system shall include equipment for accurately proportioning the components of the mixture by weight and in the proper order, controlling the cycle sequence and timing the mixing operations. Recording equipment shall monitor the batching sequence of each component of the mixture and produce a printed record of these operations on each delivery ticket, as specified herein. Material feed controls shall be automatically or manually adjustable to provide proportions within the tolerances listed below for any batch size.

An asterisk (*) shall be automatically printed next to any individual batch weight(s) exceeding the tolerances in ASTM D 995 section 8.7.3. The entire batching and mixing interlock cut-off circuits shall interrupt and stop the automatic batching operations when an error exceeding the acceptable tolerance occurs in proportioning.

There must be provisions so that scales are not manually adjusted during the printing process. In addition, the system shall be interlocked to allow printing only when the scale has come to a complete rest. A unique printed character (m) shall automatically be printed on the truck and batch plant printout when the automatic batching sequence is interrupted or switched to auto-manual or full manual during proportioning. For each day's production, each project shall be provided a clear, legible copy of these recordings on each delivery ticket.

Aggregates: The Contractor shall ensure that aggregate stockpiles are managed to provide uniform gradation and particle shape, prevent segregation and cross contamination in a manner acceptable to the Engineer. For drum plants only, the Contractor shall determine the percent moisture content at a minimum, prior to production and half way through production.

Mixture: The dry and wet mix times shall be sufficient to provide proper coating (minimum 95% as determined by AASHTO T 195(M)) of all particles with bitumen and produce a uniform mixture.

The Contractor shall make necessary adjustments to ensure all types of bituminous concrete mixtures contain no more than 0.5% moisture throughout when tested in accordance with AASHTO T 329.

RAP: The Contractor shall indicate the percent of RAP, the moisture content (as a minimum determined twice daily – prior to production and halfway through production), and the net dry weight of RAP added to the mixture on each truck ticket. For each day of production, the production shall conform to the job mix formula and RAP percentage and no change shall be made without the prior approval of the Engineer.

Asphalt Binder: The last day of every month, a binder log shall be submitted when the monthly production for the Department exceeds 5000 tons. Blending of PG binders from different suppliers or grades at the bituminous concrete production facility is strictly prohibited.

Warm mix additive: For mechanically foamed WMA, the maximum water injection rate shall not exceed 2.0% water by total weight of binder and the water injection rate shall be constantly monitored during production.

Field Laboratory: The Contractor shall furnish the Engineer an acceptable field laboratory at the production facility to test bituminous concrete mixtures during production. The field laboratory shall have a minimum of 300 square feet, have a potable water source and drainage in accordance with the CT Department of Public Health Drinking Water Division, be equipped with all necessary testing equipment as well as with a PC, printer, and telephone with a dedicated hard-wired phone line. In addition, the PC shall have a high speed internet connection with a minimum upstream of 384 Kbps and a functioning web browser with unrestricted access to <https://ctmail.ct.gov>. This equipment shall be maintained in clean and good working order at all times and be made available for use by the Engineer.

The laboratory shall be equipped with a suitable heating system capable of maintaining a minimum temperature of 65°F. It shall be clean and free of all materials and equipment not associated with the laboratory. Windows shall be installed to provide sufficient light and ventilation. During summer months adequate cooling or ventilation must be provided so the indoor air temperature shall not exceed the ambient outdoor temperature. Light fixtures and outlets shall be installed at convenient locations, and a telephone shall be within audible range of the testing area. The laboratory shall be equipped with an adequate workbench that has a suitable length, width, and sampling tables, and be approved by the Engineer.

The field laboratory testing apparatus, supplies, and safety equipment shall be capable of performing all tests in their entirety that are referenced in AASHTO R 35(M), *Standard Practice for Superpave Volumetric Design for Hot-Mix Asphalt (HMA)* and AASHTO M 323, *Standard Specification for Superpave Volumetric Mix Design*. In addition, the quantity of all equipment and supplies necessary to perform the tests must be sufficient to initiate and complete the number of tests identified in Table M.04.03-2 for the quantity of mixture produced at the facility on a daily basis. The Contractor shall ensure that the Laboratory is adequately supplied at all times during the course of the project with all necessary testing materials and equipment.

The Contractor shall maintain a list of laboratory equipment used in the acceptance testing processes including but not limited to, balances, scales, manometer/vacuum gauge, thermometers, gyratory compactor, clearly showing calibration and/or inspection dates, in accordance with AASHTO R-18. The Contractor shall notify the Engineer if any modifications are made to the equipment within the field laboratory. The Contractor shall take immediate action to replace, repair, and/or recalibrate any piece of equipment that is out of calibration, malfunctioning, or not in operation.

M.04.02—Mix Design and Job Mix Formula (JMF)

1. Marshall Method - Class 1, 2, 3, 4, 5, 5A, 5B and 12:

Requirements: When specified, the Marshall method shall be employed to develop a bituminous concrete mix design that includes a JMF consisting of target values for gradation and bitumen content for each class of bituminous concrete designated for the project in accordance with the latest Asphalt Institute's MS-2 manual. Each class of bituminous concrete must meet the requirements as shown in Table M.04.02-1.

Basis of Approval: The Contractor shall submit to the Engineer a request for approval of the JMF annually in accordance with one of the methods described herein. Prior to the start of any paving operations, the JMF and production percentage of bitumen must be accepted by the Engineer, and the Contractor must demonstrate the ability to meet the accepted JMF and production percentage of bitumen for each class of mixture. Additionally, the fraction of material retained between any two consecutive sieves shall not be less than 4%.

The Engineer will test each class of mixture for compliance with the submitted JMF and Table M.04.02-1. The maximum theoretical density (Gmm) will be determined by AASHTO T 209(M). If the mixture does not meet the requirements, the JMF shall be adjusted within the ranges shown in Table M.04.02-1 until an acceptable mixture is produced. All equipment, tests and computations shall conform to the Marshall method in accordance with AASHTO T 245(M).

An accepted JMF from the previous operating season may be acceptable to the Engineer provided that there are no changes in the sources of supply for the coarse aggregate, fine aggregate, recycled material (if applicable) and the plant operation had been consistently producing acceptable mixture.

The Contractor shall not change sources of supply after a JMF has been accepted. Before a new source of supply for materials is used, a new JMF shall be submitted to the Engineer for approval.

c. Marshall Mixture (Virgin): For bituminous concrete mixtures that contain no recycled material, the limits prescribed in Table M.04.02-1 govern. The Contractor shall submit to the Engineer for approval, a JMF with the individual fractions of the aggregate expressed as percentages of the total weight of the mix and the source(s) of all materials. The JMF shall indicate two bitumen contents; the JMF target percentage and a production percentage (actual amount added to mix) of bitumen for each mix class by total weight. For surface course Class 1, a 0.45 power gradation chart shall also be submitted on which is plotted the percentage passing

each sieve. The JMF shall also indicate the target temperature of completed mixture as it is dumped from the mixer and tested in accordance with Article M.04.03.

d. Marshall Mixtures with RAP: In addition to subarticles M.04.02 – 1a through c, RAP in bituminous concrete shall comply with requirements stated in Article M.04.01, and as stated herein. Upon approval of the Engineer, a maximum of 15% RAP may be used with no binder grade modification. RAP material shall not be used with any other recycling option.

The Contractor may increase the RAP percentage in 5% increments up to a maximum of 30% provided a new JMF is accepted by the Engineer. The following information shall be included in the JMF submittal:

Gradation and asphalt content of the RAP.

Percentage of RAP to be used.

Virgin aggregate source(s).

Total binder content based on total mixture weight.

Production pull percentage of added virgin binder based on total mixture weight.

Gradation of combined bituminous concrete mixture (including RAP).

Grade of virgin added, if greater than 15% of total mix weight.

e. Marshall Mixture with CRCG: In addition to subarticle M.04.02 – 1a through c, for bituminous concrete that contains CRCG, the Contractor shall submit a materials certificate to the Engineer stating that the mixture and its components comply with requirements stated in subarticle M.04.01 - (6). Additionally, 1% hydrated lime, or other accepted non-stripping agent, shall be added to all mixtures containing CRCG. CRCG material shall not be used with any other recycling option.

2. Cold Patch Method - Class 5, 5A, 5B:

a. Requirements: This mixture must be capable of being stockpiled and workable at all times. A non-stripping agent accepted by the Engineer shall be used in accordance with manufacturer's recommendations. The Contractor shall take necessary steps to ensure that this mixture uses aggregate containing no more than 1% moisture and is not exposed to any rain, snow, or standing water for a period of 6 hours after being mixed. This mixture shall be mixed and stockpiled at the point of production on a paved surface at a height not greater than 4 feet during the first 48 hours prior to its use.

Class 5A mixture shall have 3/8 to 1/2 inch polypropylene fibers that have been approved by the Engineer added at a rate of 6 pounds per ton of mixture.

Class 5B mixture shall have 1/4 inch polyester fibers that have been approved by the Engineer added at the rate of 2 1/2 pounds per ton of mixture.

Class 5 mixture shall not contain fibers.

b. Basis of Approval: The aggregates, fibers and binder (MC-250) shall meet the requirements as specified in sub articles M.04.01-1 through 4 and in Table M.04.02-1. The use of recycled material is not permitted with these classes of bituminous concrete. Mixtures not

conforming to the binder content as shown in Table M.04.02-1 shall be subject to rejection. There is a two test minimum per day of production. Mixtures not conforming to the gradation as shown in Table M.04.02-1 shall be subject to payment adjustment as specified in Section 4.06.

TABLE M.04.02 – 1 MASTER RANGES FOR MARSHALL BITUMINOUS-CONCRETE MIXTURES

Notes: (a) 75 blow (Marshall Criteria). (b) 3-6% when used for a roadway wearing surface. (c) For divided highways with 4 or more lanes, a stability of 1500 lbs is required. (d) Contains an accepted non-stripping compound. (e) To help prevent stripping, the mixed material will be stockpiled on a paved surface and at a height not greater than 4 feet during the first 48 hours. (f) As determined by AASHTO T 245(M). (g) The percent passing the #200 sieve shall not exceed the percentage of bituminous asphalt binder determined by AASHTO T 164 or AASHTO T 308(M). (h) Mixture with 5% or more aggregate retained on ¾" sieve. (i) Mixtures finer than condition (h) above. (j) Class 5 mixture shall contain no fibers. Class 5A mixture shall have 3/8 to ½ inch polypropylene fibers that have been previously accepted by the Engineer added at a minimum rate of 6 pounds per ton of mixture. Class 5B mixture shall have ¼ inch polyester fibers that have been previously accepted by the Engineer added at the minimum rate of 2 1/2 pounds per ton of mixture

CLASS	1	2	3	4	12	5 (e)(j)	5A (e)(j)	5B (e)(j)	JMF % Tol. (±)
Grade of PG	PG 64-22	PG 64-22	PG 64-22	PG 64-22	PG 64-22	MC-250 (d)	MC-250 (d)	MC-250 (d)	
Binder content %	5.0 – 6.5	5.0 – 8.0	6.5 - 9.0	4.0 - 6.0	7.5 - 10.0	6.0 - 7.5	6.0 - 7.5	6.0 - 7.5	0.4
Sieve Size	Percent Passing (%)								
# 200	3.0 – 8.0 (g)	3.0 – 8.0 (g)	3.0 – 8.0 (g)	0.0 – 5.0 (g)	3.0 – 10.0 (g)	0.0 - 2.5	0.0 - 2.5	0.0 - 2.5	2.0
# 50	6 – 26	8 – 26	10 - 30	5 - 18	10 - 40				4
# 30	10 - 32	16 - 36	20 - 40		20 - 60	2 - 15	2 – 15	2 - 15	5
# 8	28 - 50	40 - 64	40 - 70	20 - 40	60 - 95	10 - 45	10 – 45	10 - 45	6
# 4	40 - 65	55 - 80	65 - 87	30 - 55	80 - 95	40 - 100	40 – 100	40 - 100	7
¼"									
3/8 "	60 - 82	90 - 100	95 - 100	42 - 66	98 - 100	100	100	100	8
½ "	70 - 100	100	100		100				8
¾"	90 - 100			60 - 80					8
1"	100								
2"				100					
Additionally, the fraction of material retained between any two consecutive sieves shall not be less than 4%									
Mixture Temperature									
Binder	325°F maximum					140-185° F			
Aggregate	280-350° F					100-175° F			
Mixtures	265-325° F				275-325°F	120-175° F		25 °F	
Mixture Properties									
VOIDS - %	3.0 – 6.0 (a)	2.0 – 5.0 (b)	0 – 4.0		0 - 5.0 (a)				
Stability (f) lbs. min.	1200 (c)	1000	1000		1000				
FLOW (f) in.	.08 - .15	.08 - .15	.08 - .18		.08 - .15				
VMA % - min.	15(h) :16 (i)								

3. Superpave Design Method – S0.25, S0.375, S0.5, and S1

Requirements: The Contractor or its representative shall design and submit Superpave mix designs annually for approval. The design laboratory developing the mixes shall be approved by the Engineer. The mix design shall be based on the specified Equivalent Single-Axle Loads (ESAL). Each bituminous concrete mix type must meet the requirements shown in Tables M.04.02-2 thru Table M.04.02-5 and in accordance with AASHTO M 323(M) and AASHTO R 35(M). The mix design shall include the nominal maximum aggregate size and a JMF consisting of target values for gradation and bitumen content for each bituminous concrete mix type designated for the project.

The contractor shall provide test results with supporting documentation from an AASHTO Materials Reference Laboratory (AMRL) with the use of NETTCP Certified Technicians for the following tests;

Aggregate consensus properties for each type & level, as specified in Table M.04.02-3. In addition the G_{sa} , G_{sb} , P_{wa} shall also be provided for each component aggregate.

New mixes shall be tested in accordance with AASHTO T 283(M) *Standard Method of Test for Resistance of Compacted Hot-Mix Asphalt (HMA) to Moisture-Induced Damage*, (TSR). The compacted specimens may be fabricated at a bituminous concrete facility and then tested at an AMRL accredited facility.

The AASHTO T 283(M) test results, specimens, and corresponding JMF sheet (Form MAT-429s) shall be submitted by the Contractor for review.

The Contractor shall supply the Engineer with 1 gallon of the specified PG binder and 1 gallon of the same PG binder with the warm mix additive blended into it. The MSDS for the WMA additive shall be included with every submittal.

In addition, minimum binder content values apply to all types of bituminous concrete mixtures, as stated in Table M.04.02-5. For mixtures containing RAP, the virgin production and the anticipated proportion of binder contributed by the RAP cannot be less than the total permitted binder content value for that type nor the JMF minimum binder content.

Superpave Mixture (virgin): For bituminous concrete mixtures that contain no recycled material, the limits prescribed in Tables M.04.02-2 thru Table M.04.02-5 apply. The Contractor shall submit a JMF, on a form provided by the Engineer, with the individual fractions of the aggregate expressed as percentages of the total weight of the mix and the source(s) of all materials to the Engineer for approval. The JMF shall indicate the corrected target binder content and applicable binder correction factor (ignition oven or extractor) for each mix type by total weight of mix. The mineral filler (dust) shall be defined as that portion of blended mix that passes the #200 sieve by weight when tested in accordance with AASHTO T 30(M). The dust-to-effective asphalt (D/Pbe) ratio shall be between 0.6 and 1.2 by weight. The dry/wet mix times and hot bin proportions (batch plants only) for each type shall be included in the JMF.

The percentage of aggregate passing each sieve shall be plotted on a 0.45 power gradation chart and shall be submitted for all bituminous concrete mixtures. This chart shall delineate the percentage of material passing each test sieve size as defined by the JMF. The percentage of aggregate passing each standard sieve shall fall within the specified control points, but outside the restricted zone limits as shown in Tables M.04.02-2 thru Table M.04.02-5. Mixes with documented performance history which pass through the restricted zone may be permitted for use as long as all other physical and volumetric criteria meets specifications as specified in Tables M.04.02-2 thru Table M.04.02-5 and with prior approval from the Engineer. A change in the JMF requires that a new chart be submitted.

Superpave Mixtures with RAP: Use of approved RAP may be allowed with the following conditions:

RAP amounts up to 15% may be used with no binder grade modification.

RAP amounts up to 20% may be used provided a new JMF is approved by the Engineer. The JMF submittal shall include the grade of virgin binder added and test results that show the combined binder (recovered binder from the RAP, virgin binder at the mix design proportions and warm mix asphalt additive if used) meets the requirements of the specified binder grade.

Unless approved by the Engineer, RAP material shall not be used with any other recycling option.

Basis of Approval: On an annual basis, the Contractor shall submit to the Engineer any bituminous concrete mix design, and JMF anticipated for use on Department projects. Prior to the start of any paving operations, the mix design and JMF must be approved by the Engineer. Bituminous concrete mixture supplied to the project without an approved mix design and JMF will be rejected. The following information must be included in the mix design submittal:

Gradation, specific gravities and asphalt content of the RAP,
Source of RAP and percentage to be used.

Warm mix Technology and manufacturer's recommended additive rate and tolerances, mixing and compaction temperature ranges for the mix with and without the warm-mix technology incorporated.

Result of TSR testing, and if applicable Anti-strip manufacturer, and dosage rate.
Target Temperature at plant discharge.

Note – Testing to be performed shall be done in accordance with section M.04.03.

The JMF shall be accepted if the Plant mixture and materials meet all criteria as specified in Tables M.04.02-2 thru Table M.04.02-5. If the mixture does not meet the requirements, the contractor shall adjust the JMF within the ranges shown in Tables M.04.02-2 thru Table M.04.02-5 until an acceptable mixture is produced. All equipment, tests, and computations shall conform to the latest AASHTO R-35(M) and AASHTO M-323(M).

Any JMF, once approved, shall only be acceptable for use when it is produced by the designated plant, it utilizes the same component aggregates and binder source, and it continues to meet all criteria as specified herein, and component aggregates are maintained within the tolerances shown in Table M.04.02-2.

The Contractor shall not change any component source of supply including consensus properties after a JMF has been accepted. Before a new source of materials is used, a revised JMF shall be submitted to the Engineer for approval. Any approved JMF applies only to the plant for which it was submitted. Only one mix with one JMF will be approved for production at any one time. Switching between approved JMF mixes with different component percentages or sources of supply is prohibited.

Superpave mixture with CRCG: In addition to subarticles M.04.02 – 3 a through c, for bituminous concrete mixtures that contain CRCG, the Contractor shall submit a materials certificate to the Engineer stating that the CRCG complies with requirements stated in Article M.04.01, as applicable. Additionally, 1% hydrated lime, or other accepted non-stripping agent, shall be added to all mixtures containing CRCG. CRCG material shall not be used with any other recycling option.

Mix Status: Each facility will have each type of bituminous concrete mixture evaluated based on the previous year of production, for the next construction paving season, as determined by the Engineer. Based on the rating a type of mixture receives it will determine whether the mixture can be produced without the completion of a PPT. Ratings will be provided to each bituminous concrete producer annually prior to the beginning of the paving season.

The rating criteria are based on compliance with Air Voids and Voids in Mineral Aggregate (VMA) as indicated in Table M.04.03-3: *Superpave Master Range for Bituminous Concrete Mixture Production*, and are as follows:

Criteria A: Based on Air Voids. Percentage of acceptance results with passing air voids.

Criteria B: Based on Air Voids and VMA. The percentage of acceptance results with passing VMA, and the percentage of acceptance results with passing air voids, will be averaged.

The final rating assigned will be the lower of the rating obtained with Criteria A or Criteria B.

Ratings are defined as:

“A” – Approved:

A rating of “A” is assigned to each mixture type from a production facility with a current rating of 70% passing or greater.

“PPT” – Pre-Production Trial:

Rating assigned to each mixture type from a production facility when:
there are no passing acceptance production results submitted to the Department from the previous year;

there is a source change in one or more aggregate components from the JMF on record by more than 10% by weight;
 there is a change in RAP percentage ,
 the mixture has a rating of less than 70% from the previous season;
 a new JMF not previously submitted.

Bituminous concrete mixtures rated with a “PPT” cannot be shipped or used on Department projects. A passing “PPT” test shall be performed with NETTCP certified personnel on that type of mixture by the bituminous concrete producer and meet all specifications (Table M.04.02-2 Table M.04.02-5) before production shipment may be resumed.

Contractors that have mix types rated a “PPT” may use one of the following methods to change the rating to an “A.”

Option A: Schedule a day when a Department inspector can be at the facility to witness a passing “PPT” test or,

Option B: When the Contractor or their representative performs a “PPT” test without being witnessed by an inspector, the Contractor shall submit the test results and a split sample including 2 gyratory molds, 5,000 grams of boxed bituminous concrete for binder and gradation determination, and 5,000 grams of cooled loose bituminous concrete for Gmm determination for verification testing and approval. Passing verifications will designate the bituminous concrete type to be on an “A” status. Failing verifications will require the contractor to submit additional trials.

Option C: When the Contractor or their representative performs a “PPT” test without being witnessed by a Department inspector, the Engineer may verify the mix in the Contractor’s laboratory. Passing verifications will designate the bituminous concrete type to be an “A” status. Failing verifications will require the Contractor to submit additional trials.

When Option (A) is used and the “PPT” test meets all specifications, the “PPT” test is considered a passing test and the rating for that mix is changed to “A”. When the “PPT” test is not witnessed, the “PPT” Option (B) or (C) procedure must be followed. If the “PPT” Option (B) procedure is followed, the mixtures along with the test results must be delivered to the Materials Testing Lab. The test results must meet the “C” tolerances established by the Engineer. The tolerance Table is included in the Department’s current QA Program for Materials, Acceptance and Assurance Testing Policies and Procedures.

“U” – No Acceptable Mix Design on File:

Rating assigned to a type of mixture that does not have a JMF submitted, or the JMF submitted has not been approved, or is incomplete. A mix design or JMF must be submitted annually seven (7) days prior in order to obtain an “A,” or “PPT” status for that mix. A “U” will be used only to designate the mix status until the mix design has been approved, and is accompanied with all supporting data as specified. Bituminous concrete mixtures rated with a “U” cannot be used on Department projects.

TABLE M.04.02– 2: SUPERPAVE MASTER RANGE FOR BITUMINOUS CONCRETE MIXTURE DESIGN CRITERIA

Notes: (1) Minimum Pb as specified in Table M.04.02-5. (2) Voids in Mineral Aggregates shall be computed as specified herein. (3) Control point range is also defined as the master range for that mix. (4) Dust is considered to be the percent of materials passing the #200 sieve. (5) For WMA, lower minimum aggregate temperature will require Engineer's approval. (6) For WMA and PMA, the mix temperature shall meet manufacturer's recommendations.

Sieve	S0.25				S0.375				S0.5				S1			
	CONTROL POINTS ⁽³⁾		RESTRICTED ZONE		CONTROL POINTS ⁽³⁾		RESTRICTED ZONE		CONTROL POINTS ⁽³⁾		RESTRICTED ZONE		CONTROL POINTS ⁽³⁾		RESTRICTED ZONE	
inches	Min (%)	Max (%)	Max (%)	Min (%)	Min (%)	Max (%)	Min (%)	Max (%)	Min (%)	Max (%)	Min (%)	Max (%)	Min (%)	Max (%)	Min (%)	Max (%)
2.0	-	-	-	-	-	-	-	-	-	-	-	-	-	-	-	-
1.5	-	-	-	-	-	-	-	-	-	-	-	-	100	-	-	-
1.0	-	-	-	-	-	-	-	-	-	-	-	-	90	100	-	-
3/4	-	-	-	-	-	-	-	-	100	-	-	-	-	90	-	-
1/2	100	-	-	-	100	-	-	-	90	100	-	-	-	-	-	-
3/8	97	100	-	-	90	100	-	-	-	90	-	-	-	-	-	-
#4	-	90	-	-	-	90	-	-	-	-	-	-	-	-	39.5	39.5
#8	32	67	47.2	47.2	32	67	47.2	47.2	28	58	39.1	39.1	19	45	26.8	30.8
#16	-	-	31.6	37.6	-	-	31.6	37.6	-	-	25.6	31.6	-	-	18.1	24.1
#30	-	-	23.5	27.5	-	-	23.5	27.5	-	-	19.1	23.1	-	-	13.6	17.6
#50	-	-	18.7	18.7	-	-	18.7	18.7	-	-	15.5	15.5	-	-	11.4	11.4
#100	-	-	-	-	-	-	-	-	-	-	-	-	-	-	-	-
#200	2.0	10.0	-	-	2.0	10.0	-	-	2.0	10.0	-	-	1.0	7.0	-	-
Pb ⁽¹⁾	-	-	-	-	-	-	-	-	-	-	-	-	-	-	-	-
VMA ⁽²⁾ (%)	16.0 ± 1				16.0 ± 1				15.0 ± 1				13.0 ± 1			
VA (%)	4.0 ± 1				4.0 ± 1				4.0 ± 1				4.0 ± 1			
Gse	JMF value				JMF value				JMF value				JMF value			
Gmm	JMF ± 0.030				JMF ± 0.030				JMF ± 0.030				JMF ± 0.030			
Dust/Pbe ⁽⁴⁾	0.6 – 1.2				0.6 – 1.2				0.6 – 1.2				0.6 – 1.2			
Agg. Temp ⁽⁵⁾	280 – 350F				280 – 350F				280 – 350F				280 – 350F			
Mix Temp ⁽⁶⁾	265 – 325 F				265 – 325 F				265 – 325 F				265 – 325 F			
Design TSR	≥ 80%				≥ 80%				≥ 80%				≥ 80%			
T-283 Stripping	Minimal, as determined by the Engineer															

TABLE M.04.02–3

SUPERPAVE MASTER RANGE FOR CONSENSUS PROPERTIES OF COMBINED AGGREGATE STRUCTURES

Notes: (1) If less than 25 % of a given layer is within 4 inches of the anticipated top surface, the layer may be considered to be below 4 inches for mixture design purposes.

Traffic Level	Design ESALs (80 kN)	Coarse Aggregate Angularity ⁽¹⁾ ASTM D 5821	Fine Aggregate Angularity ⁽⁷⁾ AASHTO T 304	Flat or Elongated Particles ASTM D 4791	Sand Equivalent AASHTO T 176
-----	(million)			> # 4	-----
1*	< 0.3	55/- -	40	10	40
2	0.3 to < 3.0	75/- -	40	10	40
3	≥ 3.0	95/90	45	10	45
	Design ESALs are the anticipated project traffic level expected on the design lane, projected over a 20 year period, regardless of the actual expected design life of the roadway.	Criteria presented as minimum values. 95/90 denotes that a minimum of 95% of the coarse aggregate, by mass, shall have one fractured face and that a minimum of 90% shall have two fractured faces.	Criteria presented as minimum percent air voids in loosely compacted fine aggregate passing the #8 sieve.	Criteria presented as maximum Percent by mass of flat or elongated particles of materials retained on the #4 sieve, determined at 3:1 ratio.	Criteria presented as minimum values for fine aggregate passing the #8 sieve.

* NOTE: Level 1 for use by Towns and Municipalities ONLY.

TABLE M.04.02- 4: SUPERPAVE MASTER RANGE FOR TRAFFIC LEVELS AND DESIGN VOLUMETRIC PROPERTIES.

Traffic Level	Design ESALs	Number of Gyration by Superpave Gyrotory Compactor			Percent Density of Gmm from HMA/WMA specimen			Voids Filled with Asphalt (VFA) Based on Nominal mix size - inch			
	(million)	Nini	Ndes	Nmax	Nini	Ndes	Nmax	0.25	0.375	0.5	1
1*	< 0.3	6	50	75	≤ 91.5	96.0	≤ 98.0	70 - 80	70 - 80	70 - 80	67 - 80
2	0.3 to < 3.0	7	75	115	≤ 90.5	96.0	≤ 98.0	65 - 78	65 - 78	65 - 78	65 - 78
3	≥ 3.0	8	100	160	≤ 90.0	96.0	≤ 98.0	73 - 76	73 - 76	65 - 75	65 - 75

* NOTE: Level 1 for use by Towns and Municipalities ONLY.

TABLE M.04.02– 5: SUPERPAVE MINIMUM BINDER CONTENT BY MIX TYPE & LEVEL.

Mix Type	Level	Binder Content Minimum ⁽¹⁾
S0.25	1*	5.6
S0.25	2	5.5
S0.25	3	5.4
S0.375	1*	5.6
S0.375	2	5.5
S0.375	3	5.4
S0.5	1*	5.0
S0.5	2	4.9
S0.5	3	4.8
S1	1*	4.6
S1	2	4.5
S1	3	4.4

* NOTE: Level 1 for use by Towns and Municipalities ONLY.

M.04.03— Production Requirements:

1. Quality Control Plan and Processes: The Contractor shall submit a Quality Control Plan (QCP) for bituminous concrete production specifically for the plant producing the bituminous concrete mixture for review and approval of the Engineer on an annual basis.

The QCP shall describe the organization and procedures which the Contractor shall use to administer quality control. The QCP shall include the procedures used to control the production process, to determine when immediate changes to the processes are needed, and to implement the required changes. The QCP must detail the inspection, sampling and testing protocols to be used, and the frequency for each.

Control Chart(s) shall be developed and maintained for critical aspect(s) of the production process as determined by the Contractor. The control chart(s) shall identify the material property, applicable upper and lower control limits, and be updated with current test data. The control chart(s) shall be used as part of the quality control system to document variability of the bituminous concrete production process. The control chart(s) shall be submitted to the Engineer upon request.

The QCP shall also include the name and qualifications of a Quality Control Manager. The Quality Control Manager shall be responsible for the administration of the QCP, including compliance with the plan and any plan modifications. All daily QC sampling, inspection and test reports shall be reviewed by the Quality Control Manager and be submitted to the Engineer upon request.

The QCP shall also include the name and qualifications of any outside testing laboratory performing any QC functions on behalf of the Contractor. The QCP must also include a list of sampling & testing methods and frequencies used during production, and the names of all Quality Control personnel and their duties.

Approval of the QCP does not imply any warranty by the Engineer that adherence to the plan will result in production of bituminous concrete that complies with these specifications. The Contractor shall submit any changes to the QCP as work progresses.

2. Acceptance Sampling & Testing Methods: Acceptance samples of mixtures shall be obtained from the hauling vehicles and tested by the Contractor at the facility during each day's production.

The hauling vehicle from which samples are obtained shall be selected using stratified – random sampling based on the total estimated tons of production in accordance with ASTM D 3665, except that the first test shall be randomly taken from the first 151 tons or as directed by the Engineer.

The number of sub lots and tests required per sub lot is based on the total estimated tons of production per day as indicated in Table M.04.03-1. Quantities of the same type/level mix per plant may be combined daily for multiple state projects to determine the number of sub lots. The payment adjustment for air voids and liquid binder will be calculated per sub lot as described in Section 4.06.

An acceptance test shall not be performed within 150 tons of production from a previous acceptance test unless approved by the Engineer. Quality Control tests are not subject to this restriction. Unless otherwise tested, a minimum of one (1) acceptance test shall be performed for every four days of production at a facility for each type/level mix (days of production may or may not be consecutive days).

The Contractor shall submit all acceptance tests results to the Engineer within 24 hours or prior to the next day's production. All acceptance test specimens and supporting documentation must be retained by the Contractor. Verification testing will be performed by the Engineer on the retained specimens in accordance with the Department's QA Program for Materials.

Should the Department be unable to verify the Contractor's acceptance test result(s) due to a failure of the Contractor to retain acceptance test specimens or supporting documentation, the Contractor shall review its quality control plan, determine the cause of the nonconformance and respond in writing within 24 hours to the Engineer describing the corrective action taken at the plant. In addition the Contractor must provide supporting documentation or test results to validate the subject acceptance test result(s). The Engineer may invalidate any positive adjustments for material corresponding to the acceptance test(s). Failure of the Contractor to

adequately address quality control issues at a facility may result in suspension of production for Department projects at that facility.

Contractor personnel performing acceptance sampling and testing must be present at the facility prior to, and during production, and be certified as a NETTCP HMA Plant Technician or Interim HMA Plant Technician and be in good standing. Production of material for use on State projects must be suspended by the Contractor if such personnel are not present.

Technicians found by the Engineer to be non-compliant with NETTCP or Department policies may be removed by the Engineer from participating in the acceptance testing process for Department projects until their actions can be reviewed.

Anytime during production that testing equipment becomes inoperable, production can continue for a maximum of 1 hour. The Contractor shall obtain box sample(s) in accordance with Table M.04.03-1 to satisfy the daily acceptance testing requirement for the quantity shipped to the project. The box sample(s) shall be tested once the equipment issue has been resolved to the satisfaction of the Engineer. Production beyond 1 hour may be considered by the Engineer. Production will not be permitted beyond that day until the subject equipment issue has been resolved.

Table M.04.03 – 1: Acceptance Testing Frequency per Type/Level/Plant

Daily quantity produced in tons (lot)	Number of Sub Lots/Tests
0 to 150	0, Unless requested by the Engineer
151 to 600	1
601 to 1,200	2
1,201 to 1,800	3
1,801 or greater	1 per 600 tons or portions thereof

i. **Marshall Mix Acceptance Sampling and Testing Procedures:** When the Marshall mix design is specified, the following acceptance procedures and AASHTO test methods shall be used:

Table M.04.03 – 2: Marshall Acceptance Test Procedures

Protocol	Reference	Description
1	AASHTO T 30(M)	Mechanical Analysis of Extracted Aggregate
2	AASHTO T 40(M)	Sampling Bituminous Materials
3	AASHTO T	Binder content by Ignition Oven method (adjusted for aggregate correction factor)

Protocol	Reference	Description
	308(M)	
4	AASHTO T 245(M)	Resistance to Plastic Flow of Bituminous Mixtures Using Marshall Apparatus
5	AASHTO T 209(M)	Theoretical Maximum Specific Gravity and Density of Bituminous Paving Mixtures
6	AASHTO T 269(M)	Percent Air Voids in Compacted Dense and Open Bituminous Paving Mixtures
7	AASHTO T 329	Moisture Content of Hot-Mix Asphalt (HMA) by Oven Method

a. Cessation of Supply: Marshall Mix Production shall cease for the Project from any facility that consistently fails to produce mixture that meets the JMF and volumetric properties. The criteria for ceasing the supply of a class of mixture from any plant are as follows:

Off-Test Status: The results of AASHTO T 164 or AASHTO T 308(M) and T 30(M) will be used to determine if the mixture is within the tolerances shown in Table M.04.02-1. The Contractor will be notified that a plant is "off test" for a class of mixture when the test results indicate that any single value for bitumen content or gradation are not within the tolerances shown in Table M.04.02-1 for that class of mixture.

When multiple plants and silos are located at one site, mixture supplied to one project is considered as coming from one source for the purpose of applying the "off test" adjusted payment.

If a test indicates that the bitumen content or gradation are outside the tolerances, the Contractor may make a single JMF change on classes 1, 2, 3, 4 and 12 as allowed by the Engineer prior to any additional testing. A JMF change shall include the date and name of the Engineer that allowed it. Consecutive test results outside the requirements of Table M.04.02-1 JMF tolerances may result in rejection of the mixture.

The Engineer may cease supply of mixture from the plant when the test results from three non-consecutive samples of a class of mixture are not within the JMF tolerances or the test results from two non-consecutive samples not within the master range indicated in Table M.04.02-1 during any one production period, due to inconsistent production.

Any modification to the JMF shall not exceed 50% of the JMF tolerances indicated in Table M.04.02-1 for any given component of the mixture without approval of the Engineer. When such an adjustment is made to the bitumen, the corresponding production percentage of bitumen shall be revised accordingly.

b. Adjustments for Off Test Mixture under Cessation of Supply: The bituminous concrete plant shall cease supplying to the project:

When the test results from three consecutive samples are “off test” and not within the JMF tolerances or,

The test results from two consecutive samples are “off test” and not within the ranges indicated in Table M.04.02 – 1 or,

When the percent of material passing the minus #200 sieve material exceeds the percent of extracted bitumen content for three consecutive samples during any production period of the values stated in Table M.04.02-1:

The quantity of mixtures shipped to the project determined to be “off test” and outside the tolerances will be tabulated by the Engineer and will be adjusted in accordance with Section 4.06.

Following cessation, a trial production period will be required at the plant for that class of mixture. Use of that class of mixture from that plant will be prohibited on the Project until the plant has demonstrated the ability to consistently produce acceptable mixture.

When the Engineer has accepted the mixtures from the trial production period, the use of that mixture on the Project may resume.

ii. Superpave Mix Acceptance Sampling and Testing Procedures: When the Superpave mix design is specified, the following acceptance and AASHTO test procedures shall be used:

Table M.04.03– 3: Superpave Acceptance Testing Procedures

Protocol	Reference	Description
1	AASHTO T 168(M)	Sampling of bituminous concrete
2	AASHTO T 308(M)	Binder content by Ignition Oven method (adjusted for aggregate correction factor)
3	AASHTO T 30(M)	Gradation of extracted aggregate for bituminous concrete mixture
4	AASHTO T 312(M)	⁽¹⁾ Superpave Gyrotory molds compacted to N _{des}
5	AASHTO T 166(M)	⁽²⁾ Bulk specific gravity of bituminous concrete
6	AASHTO R 35(M)	⁽²⁾ Air voids, VMA
7	AASHTO T 209(M)	Maximum specific gravity of bituminous concrete (average of two tests)
8	AASHTO T 329	Moisture content of Production bituminous concrete

The Contractor shall perform moisture susceptibility (TSR) testing annually for all design levels of HMA-, WMA-, and PMA- S0.5 plant-produced mixtures, in accordance with the latest version of AASHTO T 283(M).

If any material source changes from the previous year, or during the production season, a mix design TSR as well as a production TSR is required for the new mixture. The AASHTO T 283(M) test shall be performed at an AASHTO Materials Reference Laboratory (AMRL) by NETTCP Certified Technicians. The test results and specimens shall be submitted to the Engineer for review. This shall be completed within 30 days from the start of production. Superpave mixtures that require anti-strip additives (either liquid or mineral) shall continue to meet all requirements specified herein for binder and bituminous concrete. The Contractor shall submit the name, manufacturer, percent used, and MSDS sheet for the anti-strip additive (if applicable) to the Engineer. In addition, compaction of samples shall be accomplished utilizing an accepted Superpave Gyratory Compactor (SGC), supplied by the Contractor. The SGC shall be located at the facility supplying mixture to the project.

Determination of Off-Test Status:

Off Test Status: Superpave mixes shall be considered “*off test*” when any Control Point Sieve, VA, VMA, and Gmm values are outside of the limits specified in Table M.04.03-3 and the computed binder content (Pb) established by AASHTO T308(M) or as documented on the vehicle delivery ticket is below the minimum binder content stated in sub article M.04.03-5. Note that further testing of samples or portions of samples not initially tested for this purpose cannot be used to change the status.

Any time the bituminous concrete mixture is considered Off-test:

1. The Contractor shall notify the Engineer (and project staff) when the plant is “*off test*” for a type of mixture. When multiple plants and silos are located at one site, mixture supplied to one project is considered as coming from one source for the purpose of applying the “*off test*” determination.
2. The Contractor must take immediate actions to correct the deficiency, minimize “*off test*” production to the project, and obtain an additional Process Control (PC) test after any corrective action to verify production is in conformance to the specifications. A PC test will not be used for acceptance and is solely for the use of the Contractor in its quality control process.

Cessation of Supply for Superpave Mixtures with no Payment Adjustment: Production of bituminous concrete shall cease for the Project from any plant that consistently fails to produce mixture that meets the JMF and volumetric properties. The quantity of Superpave mixtures shipped to the project that is “off-test” will not be adjusted for deficient mixtures.

A Contractor shall cease to supply mixture from a plant when:

Bituminous concrete mixture is “off test” on three (3) consecutive tests for VMA or Gmm, regardless of date of production due to inconsistency (i.e., small production requires 1 test per day for multiple days).

Bituminous concrete mixture is “off test” on two (2) consecutive tests for the Control Point sieves in one day’s production.

Following cessation, the Contractor shall immediately make necessary material or process corrections and run a Pre-Production Trial (PPT) for that type of mixture. Use of that type of mixture from that plant will be prohibited on the Project until the Contractor has demonstrated the ability to produce acceptable mixture from that facility. When the Contractor has a passing test and has received approval from the Engineer, the use of that mixture to the Project may resume.

Cessation of Supply for Superpave Mixtures with Payment Adjustment:

Production of bituminous concrete shall cease for the Project from any plant that consistently fails to produce mixture that meets the Superpave minimum binder content by mix type and level listed in Table M.04.02-5. The quantity of Superpave mixtures shipped to the project that is “off-test” will be adjusted for deficient mixtures in accordance with Section 4.06.

A Contractor shall cease to supply mixture from a plant when the binder content (Pb) is below the requirements of Table M.04.03-5 on the ignition oven test result after two (2) consecutive tests, regardless of the date of production.

Following cessation, the Contractor shall immediately make necessary material or process corrections and run a Pre-Production Trial (PPT) for that type of mixture. Use of that type of mixture from that plant will be prohibited on the Project until the Contractor has demonstrated the ability to produce acceptable mixture from that facility. When the Contractor has a passing test and has received approval from the Engineer, the use of that mixture to the Project may resume.

JMF Changes for Superpave Mixture Production: It is understood that a JMF change is effective from the time it was submitted forward and is not retroactive to the previous test or tests. JMF changes are permitted to allow for trends in aggregate and mix properties but every effort shall be employed by the Contractor to minimize this to ensure a uniform and dense pavement.

JMF changes to the G_{mm} or mix Absorption Correction Factor (A_{cf}) are only permitted prior to or after a production shift for all bituminous-concrete types of mixtures and only when they:

- Are requested in writing and pre-approved by the Engineer;
 - Are based on a minimum of a two test trend;
 - Are documented with a promptly submitted revised JMF on form provided by the Engineer.
- A revised JMF submittal shall include the date and name of the Engineer that allowed it.

TABLE M.04.03– 3: SUPERPAVE MASTER RANGE FOR BITUMINOUS CONCRETE MIXTURE PRODUCTION

Notes: (1) 300°F minimum after October 15. (2) Minimum Pb as specified in Table M.04.03-5 (3) Control point range is also defined as the master range for that mix. (4) JMF tolerances shall be defined as the limits for production compliance. VA & Pb payment is subject to adjustments, as defined in sub-article 4.06.04 - 2. (5) For WMA, lower minimum aggregate temperature will require Engineer's approval. (6) For WMA and/or polymer modified asphalt, the mix temperature shall meet manufacturer's recommendations. In addition, for WMA, the maximum mix temperature shall not exceed 325°F once the WMA technology is incorporated.									
	S0.25		S0.375		S0.5		S1		Tolerances
Sieve	CONTROL POINTS (4)		CONTROL POINTS (4)		CONTROL POINTS (4)		CONTROL POINTS (4)		JMF Limits (4)
inches	Min(%)	Max(%)	Min(%)	Max(%)	Min(%)	Max(%)	Min(%)	Max(%)	±Tol
2.0	-	-	-	-	-	-	-	-	
1.5	-	-	-	-	-	-	100	-	
1.0	-	-	-	-	-	-	90	100	
3/4	-	-	-	-	100	-	-	90	
1/2	100	-	100	-	90	100	-	-	
3/8	97	100	90	100	-	90	-	-	
#4	-	90	-	90	-	-	-	-	
#8	32	67	32	67	28	58	19	45	
#16	-	-	-	-	-	-	-	-	
#200	2.0	10.0	2.0	10.0	2.0	10.0	1.0	7.0	
Pb ⁽²⁾	-	-	-	-	-	-	-	-	note (2)
VMA (%)	16.0		16.0		15.0		13.0		1.0
VA (%)	4.0		4.0		4.0		4.0		1.0
Gmm	JMF value		JMF value		JMF value		JMF value		0.030
Agg. Temp ⁽⁵⁾	280 – 350F		280 – 350F		280 – 350F		280 – 350F		
Mix Temp ⁽⁶⁾	265 – 325 F ⁽¹⁾		265 – 325 F ⁽¹⁾		265 – 325 F ⁽¹⁾		265 – 325 F ⁽¹⁾		
Prod. TSR	N/A		N/A		≥80%		N/A		
T-283 Stripping	N/A		N/A		Minimal as determined by the Engineer		N/A		

TABLE M.04.03– 4: SUPERPAVE MASTER RANGE FOR TRAFFIC LEVELS AND DESIGN VOLUMETRIC PROPERTIES.

Traffic Level	Design ESALs	Number of Gyration by Superpave Gyrotory Compactor	
	(million)	Nini	Ndes
1*	< 0.3	6	50
2	0.3 to < 3.0	7	75
3	≥3.0	8	100

* NOTE: Level 1 for use by Towns and Municipalities ONLY.

TABLE M.04.03– 5: SUPERPAVE MINIMUM BINDER CONTENT BY MIX TYPE & LEVEL.

Mix Type	Level	Binder Content Minimum ⁽¹⁾
S0.25	1*	5.6
S0.25	2	5.5
S0.25	3	5.4
S0.375	1*	5.6
S0.375	2	5.5
S0.375	3	5.4
S0.5	1*	5.0
S0.5	2	4.9
S0.5	3	4.8
S1	1*	4.6
S1	2	4.5
S1	3	4.4

* NOTE: Level 1 for use by Towns and Municipalities ONLY.

Table M.04.03-6:

Modifications to Standard AASHTO and ASTM Test Specifications and Procedures.

AASHTO Standard Specification	
Reference	Modification
M 320	1. Mass change for PG 64-22 shall be a maximum loss of 0.5% when tested in accordance with AASHTO T 240. 2. The two bottles used for the mass change determination may be re-heated and used for further testing.
AASHTO Standard Methods of Test	
Reference	Modification
T 27	Section 7.7 Samples are not washed
T 30	Section 6.2 thru 6.5 Samples are not routinely washed
T 168	Samples are taken at one point in the pile. All types of bituminous concrete except

	<p>Class 4 are scooped from the sample container instead of remixing and quartering. (Method verified by laboratory study).</p> <p>Samples from a hauling vehicle are taken from only one point instead of three as specified.</p> <p>Selection of Samples: Sampling is equally important as the testing, and the sampler shall use every precaution to obtain samples that are truly representative of the bituminous mixture.</p> <p>Box Samples: In order to enhance the rate of processing samples taken in the field by construction or maintenance personnel the samples will be tested in the order received and data processed to be determine conformance to material specifications and to prioritize inspections by laboratory personnel.</p>
T 195	Section 4.3 only one truck load of mixture is sampled. Samples are taken from opposite sides of the load.
T 209	<p>Article 9.5.1 Bowl is suspended 2 minutes prior to reading rather than 10 minutes. This makes no significant difference in results.</p> <p>Section 7.2 The average of two bowls is used proportionally in order to satisfy minimum mass requirements.</p> <p>8.3 Omit Pycnometer method.</p>
T 245	<p>Article 3.3.2 A compacting temperature of 140 to 146°C (284 to 295°F) is used</p> <p>Article 3.5.2 Seventy-five (75) blows per side are used on Classes 1 and 12, per ConnDOT design requirements</p> <p>Section 3.1 for production testing: one specimen is molded for each extraction test for production over 275 metric tons/day (300 tons/day). Other mixtures: two specimens per extraction test.</p>
T 283	When foaming technology is used, the material used for the fabrication of the specimens shall be cooled to room temperature, and then reheated to the manufactures recommended compaction temperature prior to fabrication of the specimens.
T 308	<p>In addition to the standard testing procedure, the Department has adopted a procedure that addresses a correction factor that is calculated using the composite aggregate percentages (Composite Aggregate Correction Factor Method (CACF)).</p> <p>The aggregate is burned in compliance with the standard AASHTO procedure Method A exclusively. All modifications are listed for this method only.</p> <p>A2.2 and A2.3 Omit</p> <p>A2.4 Omit. Replace with: Determine an aggregate gradation for each aggregate component “blank” in accordance with T30.</p> <p>A2.5 Omit. Replace with: The individual aggregate samples are to be dried in an oven at a maximum temperature of 148 ± 5°C (300 ± 9° F) to a constant weight. RAP samples are to be oven dried at a maximum temperature of 110 ± 5°C (230 ± 9° F) to a constant weight. RAP samples will be burned for total binder content</p>

	<p>only and not to arrive at a correction factor for a mixture. A2.6 and A2.7 and A2.8 Omit. A2.8.1 Omit Note 2 A2.9 Omit. Replace with: Perform a gradation analysis on the residual aggregate in accordance with T30 and compare it to the gradation performed prior to burning. A2.9.1 and A2.9.2 Omit</p> <p>The correction factors for each size aggregate are provided by the Contractor to the Engineer prior to the Annual Plant Inspection. The Engineer may verify the correction factors. The Composite Aggregate Correction Factor (CACF) for any mixture may be calculated by summing the result of the correction factor for each individual aggregate multiplied by the percentage of that aggregate in the overall mixture. (Note: All correction factors must be re-calculated every time the percentage of any aggregate changes within the mixture.)</p> <p>If the average corrected Pb content from the ignition oven differs by 0.3% or more from the average bituminous concrete facility production weigh ticket in five (5) consecutive tests regardless of the production date (moving average), the Contractor shall immediately investigate, determine an assignable cause and correct the issue. When two consecutive moving average differences are 0.3% or more, the Engineer may require a new correction factor calculation for all the aggregate components in the mix.</p> <p>In addition to the standard testing procedure, the Department has adopted a procedure that addresses the time involved between sampling the hot-mix asphalt specimen and the beginning of the test. 6.3 Omit. Replace with: The test specimen must be ready to be placed in an approved ignition furnace for testing within ten minutes of being obtained from the hauling vehicle and the test shall start immediately after.</p>
T 331	6.1 Cores are dried to a constant mass prior to testing using a core-dry machine.
AASHTO Standard Recommended Practices	
Reference	Modification

R 35**Volumetric Calculations of VMA and Correction Factor**

VMA_a - Voids in Mineral Aggregate from (V_a + V_b) the mix:

A. VMA calculated from the mix shall be determined in accordance with *Formula 5.16.1A*. It can be correlated that the VMA calculated from AASHTO R-35 is equivalent to VMA_a when the $Pb_a \times (100 - Pb_t) / 100$ is known and substituted for A_{cf}, as shown in *Formula 5.16.1A (ii)*. Test results from VMA_a shall therefore be required to meet all contract specifications. Values of VMA_a that are out of specifications during production may be cause for the contractor to determine assignable reason, take corrective action, and modify the Job Mix Formula (JMF), as needed. Continued VMA_a data that is out of specifications may be cause for the Engineer to order cessation of supply.

Formula 5.16.1A. Determining the VMA of bituminous concrete by the mix or air voids & effective binder method:

$$VMA_a = V_a + \left[\frac{(Gmb_d \times (Pb_t - A_{cf}))}{G_b} \right]$$

Where: VMA_a = VMA calculated from plant production mix (V_a + V_b)
 Gmb_d = Bulk specific gravity as determined by AASHTO T 166(M)
 Pb_t = Total Binder Content (corrected) by AASHTO T 308(M)
 A_{cf} = Absorption correction factor provided by Contractor (refer to B. i and ii)

B. Determining the bituminous concrete mix binder correction factor for each class by use of percent absorption of water by AASHTO T 84/85, AASHTO M 323 and D_f method. This value shall be performed by the Contractor during the mix design only and submitted as a JMF value. Two methods for determining the A_{cf} are shown, although method (i) will be the desired method to be used. Both methods are equivalent when the G_{sa}, G_{sb} and P_{wa} are recent and valid for the mix.

$$A_{cf} = Df \times Pwa \times (100 - Pb_t) / 100$$

$$A_{cf} = (Pb_a \text{ from annual JMF submittal}) \times (100 - Pb_t) / 100$$

Where: D_f = as determined by Formula 5.16.1B.

P_{wa} = as determined by AASHTO T 84/85

P_b_a = as determined by AASHTO M 323 (from annual JMF submittal)

D_f (Density Factor): The Contractor shall calculate the bituminous concrete

	<p>mix design D_f (derived from formula X1.2 APPENDIX X1 of AASHTO R 35) for each class of material, in accordance with Formula 5.16.1B.</p> <p>Formula 5.16.1B. Determining the Density Factor (D_f) of mix design bituminous concrete:</p> $D_f = \left(\frac{G_{se} - G_{sb}}{G_{sa} - G_{sb}} \right)$ <p>Where: D_f = Density Factor or multiplier determined by AASHTO R-35(M) G_{se} = Effective Specific Gravity determined by AASHTO M-323 at plant G_{sa} = Apparent Specific Gravity determined by AASHTO T 84/85 of mix design G_{sb} = Bulk Specific Gravity determined by AASHTO T 84/85 of mix design</p>
<p>R 26</p>	<p>Quality Control Plans must be formatted in accordance with AASHTO R 26, certifying suppliers of performance-graded asphalt binders, Section 9.0, Suppliers Quality Control Plan, and “NEAUPG Model PGAB QC Plan.”</p> <p>The Department requires that all laboratory technician(s) responsible for testing PG-binders be certified or Interim Qualified by the New England Transportation Technician Certification Program (NETTCP) as a PG Asphalt Binder Lab Technician.</p> <p>Sampling of asphalt binders should be done under the supervision of qualified technician. NECTP “Manual of Practice,” Chapter 2 Page 2-4 (Key Issues 1-8).</p> <p>A copy of the Manual of Practice for testing asphalt binders in accordance with the Superpave PG Grading system shall be in the testing laboratory.</p> <p>All laboratories testing binders for the Department are required to be accredited by the AASHTO Materials Reference Laboratory (AMRL).</p> <p>Sources interested in being approved to supply PG-binders to the Department by use of an “in-line blending system,” must record properties of blended material, and additives used.</p> <p>Each source of supply of PG-binder must indicate that the binders contain no additives used to modify or enhance their performance properties. Binders that are manufactured using additives, modifiers, extenders etc., shall disclose the type of additive, percentage and any handling specifications/limitations required.</p> <p>Suppliers shall provide AASHTO M-320 Table 2 testing at a minimum of once per month on one sample of material. Each supplier shall rotate the PG grade each month (including polymer-modified asphalt (PMA)), so that data can be collected for all the grades produced.</p>

END OF SECTION

SECTION I

ASPHALT PRICE ADJUSTMENTS:
BITUMINOUS CONCRETE MATERIALS COMPLETE IN PLACE

1. Asphalt price adjustments shall be applied to asphalt pavement including class 1 & 2 and shall not apply to curbing, tack coat, or hand/ sidewalk, or aprons allowed will be based on the April 2015 average of the F.O.B. terminal price per ton of unmodified PG 64-22 binder without anti-stripping agent (base average F.O.B. terminal price).

The April 2015 average shall be \$505.00 per ton.

The Asphalt Price is available on the Department of Transportation web site at:
<http://www.ct.gov/dot/asphaltadjustment>

NOTE: The same grade of asphalt cement used in establishing the base average F.O.B. terminal price shall be used in establishing the new average F.O.B. terminal price.

2. The new average F.O.B. terminal price will be determined based on the above F.O.B. terminal prices posted on the 20th of each month, hereafter known as the “Adjustment Date”, starting at time of submission of bid. However, asphalt price adjustments, in accordance with the formula below, will be effective for deliveries made on and after the first of the month (i.e., May 1, 2014) following the adjustment date.

3. The unit prices of bituminous materials purchased based on this specification will be subject to adjustment based on the following formula:

New Average FOB Terminal Price	-	Base Bid Average Terminal Price	x	Adjustment Factor Class 1- 5% Class 2- 6%	=	Price Adjustment (Per US Ton)
-----------------------------------	---	--	---	---	---	----------------------------------

NEW MONTHLY AVERAGE F.O.B TERMINAL PRICE:

The average F.O.B terminal price for unmodified PG 64-22 binder without anti-stripping agent as determined by the Department of Transportation Standard Specification, or certified F.O.B. tickets.

Asphalt price adjustment will not be allowed for materials, which do not have an asphalt cement base.

EXAMPLE:

Items #1 (Class 1)
 Base Avg. Price = \$572
 New Avg. Price = \$590
 Total Adjustment factor = 5.0% Asphalt Pavement
 $\$590 - 572 \times .05 = \0.90 per US Ton

Positive Price Adjustment number shall be added to original per Ton Bid Price

Negative Price Adjustment number shall be subtracted from original per Ton Bid Price.

SECTION J

Tentative Paving Schedule

**Borough of Naugatuck
Department of Public Works
Tentative Road Paving Schedule**

<u>Approximate</u>	<u>Location</u>	<u>Description</u>		<u>RSR</u>	<u>Length</u>	<u>Width</u>	<u>Project</u>	<u>SY</u>
<u>Schedule</u>	<u>Projects</u>	<u>From</u>	<u>To</u>					
2015	Tawney Thrush	Bear Paw	Meadow Lark Rd	61	796	30	Mill & Pave	2,653
2015	Bea Paw Road	Horton Hill Road	Tawney Thrush Road	61	602	30	Mill & Pave	2,007
2015	Andrew Mt Road	Andrew Ave	West Mountain Road	51	3869	24	Mill & Pave	10,317
2015	Andrew Ave	Rubber Ave	Old Derby Tnpk	51	2810	22	Mill & Pave	6,869
2015	High Street	City Hill	May Street	61	4488	27	Mill & Pave	13,464
2015	High Street	South Main Route 63	May Street	61	3234	26	Mill & Pave	9,343
2015	Johnson Street	John Street	High Street	49	1314	22	Mill & Pave	3,212
2015	Wooster Street	City Hill Road	Maple Hill Road	55	6366	24	Mill & Pave	16,976

It is expected that some of the following roads will be paved during spring of 2016 and be part of this contract. The remaining roads will be scheduled for future contracts.

2016	Arbor Ave	Maple Hill Street	Rustling Reed Road	69	600	30	Mill & Pave	2,000
2016	Kent Street	Mulberry	Arbor Ave	77	694	30	Mill & Pave	2,313
2016	Maple Hill Road	May Street	Horton Hill Road	63	5877	30	Mill & Pave	19,590
2016	May Street	Donovan Road	Maple Hill Road	66	6810	25	Mill & Pave	18,917
2016	Morning Mist Road	Sunburst	Dead End	66	2116	30	Mill & Pave	7,053
2016	Neumann Street	Rubber Ave	Field Street	58	543	26	Mill & Pave	1,569
2016	Rubber Ave	Meadow Street Rt 63	Brookside Ave	71	4073	34	Mill & Pave	15,387
2016	Rubber Ave	Brookside Ave	Neumann Street	63	2911	39	Mill & Pave	12,614
2016	Rubber Ave Ext	Coventry Ln	Gunntown Road	61	1351	25	Mill & Pave	3,753
2016	Rustling Reed Road	Mulberry	Morning Mist Road	72	1248	30	Mill & Pave	4,160
2016	Spring Street	Dunn Ln	Waterbury City Line	61	4179	29	Mill & Pave	13,466
2016	Sunburst Road	Rustling Reed Road	Warm Earth Road	70	1519	30	Mill & Pave	5,063

SECTION K

Prevailing Wage Rates

Project: Road Paving Program

**Minimum Rates and Classifications
for Heavy/Highway Construction**

**Connecticut Department of Labor
Wage and Workplace Standards Division**

ID#: H 20517

By virtue of the authority vested in the Labor Commissioner under provisions of Section 31-53 of the General Statutes of Connecticut, as amended, the following are declared to be the prevailing rates and welfare payments and will apply only where the contract is advertised for bid within 20 days of the date on which the rates are established. Any contractor or subcontractor not obligated by agreement to pay to the welfare and pension fund shall pay this amount to each employee as part of his/her hourly wages.

Project Number: 15-12

Project Town: Naugatuck

FAP Number:

State Number:

Project: Road Paving Program

CLASSIFICATION	Hourly Rate	Benefits
-----------------------	--------------------	-----------------

01) Asbestos/Toxic Waste Removal Laborers: Asbestos removal and encapsulation (except its removal from mechanical systems which are not to be scrapped), toxic waste removers, blasters. ****See Laborers Group 5 and 7****

1) Boilermaker	33.79	34% + 8.96
----------------	-------	------------

1a) Bricklayer, Cement Masons, Cement Finishers, Plasterers, Stone Masons	32.50	28.34
---	-------	-------

2) Carpenters, Piledrivermen	31.00	22.50
------------------------------	-------	-------

As of:

Friday, April 24, 2015

Project: Road Paving Program

2a) Diver Tenders	31.00	22.50
-------------------	-------	-------

3) Divers	39.46	22.50
-----------	-------	-------

4) Painters: (Bridge Construction) Brush, Roller, Blasting (Sand, Water, etc.), Spray	45.10	18.55
--	-------	-------

4a) Painters: Brush and Roller	31.02	18.55
--------------------------------	-------	-------

4b) Painters: Spray Only	34.02	18.55
--------------------------	-------	-------

4c) Painters: Steel Only	33.02	18.55
--------------------------	-------	-------

4d) Painters: Blast and Spray	34.02	18.55
-------------------------------	-------	-------

As of:

Friday, April 24, 2015

Project: Road Paving Program

4e) Painters: Tanks, Tower and Swing 33.02 18.55

5) Electrician (Trade License required: E-1,2 L-5,6 C-5,6 T-1,2 L-1,2 V-1,2,7,8,9) 37.27 22.25 + 3% of gross wage

6) Ironworkers: Ornamental, Reinforcing, Structural, and Precast Concrete Erection 34.47 29.74 + a

7) Plumbers (Trade License required: (P-1,2,6,7,8,9 J-1,2,3,4 SP-1,2) and Pipefitters (Including HVAC Work) (Trade License required: S-1,2,3,4,5,6,7,8 B-1,2,3,4 D-1,2,3,4 G-1, G-2, G-8, G-9) 40.31 26.82

---LABORERS----

8) Group 1: Laborer (Unskilled), Common or General, acetylene burner, concrete specialist 27.85 18.30

9) Group 2: Chain saw operators, fence and guard rail erectors, pneumatic tool operators, powdermen, air tool operator 28.10 18.30

As of:

Friday, April 24, 2015

Project: Road Paving Program

10) Group 3: Pipelayers	28.35	18.30
-------------------------	-------	-------

11) Group 4: Jackhammer/Pavement breaker (handheld); mason tenders (cement/concrete), catch basin builders, asphalt rakers, air track operators, block pavers and curb setters	28.35	18.30
--	-------	-------

12) Group 5: Toxic waste removal (non-mechanical systems)	29.85	18.30
---	-------	-------

13) Group 6: Blasters	29.60	18.30
-----------------------	-------	-------

Group 7: Asbestos Removal, non-mechanical systems (does not include leaded joint pipe)	28.85	18.30
--	-------	-------

Group 8: Traffic control signalmen	16.00	18.30
------------------------------------	-------	-------

---LABORERS (TUNNEL CONSTRUCTION, FREE AIR). Shield Drive and Liner Plate Tunnels in Free Air.---

As of:

Friday, April 24, 2015

Project: Road Paving Program

13a) Miners, Motormen, Mucking Machine Operators, Nozzle Men, Grout Men, Shaft & Tunnel Steel & Rodmen, Shield & Erector, Arm Operator, Cable Tenders	32.22	18.30 + a
---	-------	-----------

13b) Brakemen, Trackmen	31.28	18.30 + a
-------------------------	-------	-----------

---CLEANING, CONCRETE AND CAULKING TUNNEL---

14) Concrete Workers, Form Movers, and Strippers	31.28	18.30 + a
--	-------	-----------

15) Form Erectors	31.60	18.30 + a
-------------------	-------	-----------

---ROCK SHAFT LINING, CONCRETE, LINING OF SAME AND TUNNEL
IN FREE AIR:---

16) Brakemen, Trackmen, Tunnel Laborers, Shaft Laborers	31.28	18.30 + a
---	-------	-----------

As of:

Friday, April 24, 2015

Project: Road Paving Program

17) Laborers Topside, Cage Tenders, Bellman	31.17	18.30 + a
---	-------	-----------

18) Miners	32.22	18.30 + a
------------	-------	-----------

---TUNNELS, CAISSON AND CYLINDER WORK IN COMPRESSED
AIR: ----

18a) Blaster	38.53	18.30 + a
--------------	-------	-----------

19) Brakemen, Trackmen, Groutman, Laborers, Outside Lock Tender, Gauge Tenders	38.34	18.30 + a
---	-------	-----------

20) Change House Attendants, Powder Watchmen, Top on Iron Bolts	36.41	18.30 + a
---	-------	-----------

21) Mucking Machine Operator	39.11	18.30 + a
------------------------------	-------	-----------

As of:

Friday, April 24, 2015

Project: Road Paving Program

---TRUCK DRIVERS---(*see note below)

Two axle trucks	28.58	20.24 + a
-----------------	-------	-----------

Three axle trucks; two axle ready mix	28.68	20.24 + a
---------------------------------------	-------	-----------

Three axle ready mix	28.73	20.24 + a
----------------------	-------	-----------

Four axle trucks, heavy duty trailer (up to 40 tons)	28.78	20.24 + a
--	-------	-----------

Four axle ready-mix	28.83	20.24 + a
---------------------	-------	-----------

Heavy duty trailer (40 tons and over)	29.03	20.24 + a
---------------------------------------	-------	-----------

As of:

Friday, April 24, 2015

Project: Road Paving Program

Specialized earth moving equipment other than conventional type on-the road trucks and semi-trailer (including Euclids)	28.83	20.24 + a
---	-------	-----------

---POWER EQUIPMENT OPERATORS---

Group 1: Crane handling or erecting structural steel or stone, hoisting engineer (2 drums or over), front end loader (7 cubic yards or over), Work Boat 26 ft. & Over. (Trade License Required)	37.55	23.05 + a
---	-------	-----------

Group 2: Cranes (100 ton rate capacity and over); Excavator over 2 cubic yards; Piledriver (\$3.00 premium when operator controls hammer); Bauer Drill/Caisson. (Trade License Required)	37.23	23.05 + a
--	-------	-----------

Group 3: Excavator/Backhoe under 2 cubic yards; Cranes (under 100 ton rated capacity), Gradall; Master Mechanic; Hoisting Engineer (all types of equipment where a drum and cable are used to hoist or drag material regardless of motive power of operation), Rubber Tire Excavator (Drott-1085 or similar); Grader Operator; Bulldozer Fine Grade (slopes, shaping, laser or GPS, etc.). (Trade License Required)	36.49	23.05 + a
---	-------	-----------

Group 4: Trenching Machines; Lighter Derrick; Concrete Finishing Machine; CMI Machine or Similar; Koehring Loader (Skoopert)	36.10	23.05 + a
--	-------	-----------

Group 5: Specialty Railroad Equipment; Asphalt Paver; Asphalt Spreader; Asphalt Reclaiming Machine; Line Grinder; Concrete Pumps; Drills with Self Contained Power Units; Boring Machine; Post Hole Digger; Auger; Pounder; Well Digger; Milling Machine (over 24" Mandrell)	35.51	23.05 + a
--	-------	-----------

Project: Road Paving Program

Group 5 continued: Side Boom; Combination Hoe and Loader; Directional Driller. 35.51 23.05 + a

Group 6: Front End Loader (3 up to 7 cubic yards); Bulldozer (rough grade dozer). 35.20 23.05 + a

Group 7: Asphalt Roller; Concrete Saws and Cutters (ride on types); Vermeer Concrete Cutter; Stump Grinder; Scraper; Snooper; Skidder; Milling Machine (24" and Under Mandrel). 34.86 23.05 + a

Group 8: Mechanic, Grease Truck Operator, Hydroblaster, Barrier Mover, Power Stone Spreader; Welder; Work Boat under 26 ft.; Transfer Machine. 34.46 23.05 + a

Group 9: Front End Loader (under 3 cubic yards), Skid Steer Loader regardless of attachments (Bobcat or Similar); Fork Lift, Power Chipper; Landscape Equipment (including hydroseeder). 34.03 23.05 + a

Group 10: Vibratory Hammer, Ice Machine, Diesel and Air Hammer, etc. 31.99 23.05 + a

Group 11: Conveyor, Earth Roller; Power Pavement Breaker (whiphammer), Robot Demolition Equipment. 31.99 23.05 + a

As of:

Friday, April 24, 2015

Project: Road Paving Program

Group 12: Wellpoint Operator. 31.93 23.05 + a

Group 13: Compressor Battery Operator. 31.35 23.05 + a

Group 14: Elevator Operator; Tow Motor Operator (Solid Tire No Rough Terrain). 30.21 23.05 + a

Group 15: Generator Operator; Compressor Operator; Pump Operator; Welding Machine Operator; Heater Operator. 29.80 23.05 + a

Group 16: Maintenance Engineer/Oiler 29.15 23.05 + a

Group 17: Portable asphalt plant operator; portable crusher plant operator; portable concrete plant operator. 33.46 23.05 + a

Group 18: Power Safety Boat; Vacuum Truck; Zim Mixer; Sweeper; (minimum for any job requiring CDL license). 31.04 23.05 + a

As of:

Friday, April 24, 2015

Project: Road Paving Program

**NOTE: SEE BELOW

---LINE CONSTRUCTION---(Railroad Construction and Maintenance)---

20) Lineman, Cable Splicer, Technician	45.43	6.25%+19.20
--	-------	-------------

21) Heavy Equipment Operator	40.89	6.25%+17.18
------------------------------	-------	-------------

22) Equipment Operator, Tractor Trailer Driver, Material Men	38.62	6.25%+16.68
--	-------	-------------

23) Driver Groundmen	24.99	6.25%+10.87
----------------------	-------	-------------

23a) Truck Driver	34.07	6.25%+15.41
-------------------	-------	-------------

As of:

Friday, April 24, 2015

Project: Road Paving Program

---LINE CONSTRUCTION---

24) Driver Groundmen	30.92	6.5% + 9.70
----------------------	-------	-------------

25) Groundmen	22.67	6.5% + 6.20
---------------	-------	-------------

26) Heavy Equipment Operators	37.10	6.5% + 10.70
-------------------------------	-------	--------------

27) Linemen, Cable Splicers, Dynamite Men	41.22	6.5% + 12.20
---	-------	--------------

28) Material Men, Tractor Trailer Drivers, Equipment Operators	35.04	6.5% + 10.45
--	-------	--------------

Project: Road Paving Program

Welders: Rate for craft to which welding is incidental.

**Note: Hazardous waste removal work receives additional \$1.25 per hour for truck drivers.*

***Note: Hazardous waste premium \$3.00 per hour over classified rate*

ALL Cranes: When crane operator is operating equipment that requires a fully licensed crane operator to operate he receives an extra \$1.00 premium in addition to the hourly wage rate and benefit contributions:

1) Crane handling or erecting structural steel or stone; hoisting engineer (2 drums or over)

2) Cranes (100 ton rate capacity and over) Bauer Drill/Caisson

3) Cranes (under 100 ton rated capacity)

Crane with 150 ft. boom (including jib) - \$1.50 extra

Crane with 200 ft. boom (including jib) - \$2.50 extra

Crane with 250 ft. boom (including jib) - \$5.00 extra

Crane with 300 ft. boom (including jib) - \$7.00 extra

Crane with 400 ft. boom (including jib) - \$10.00 extra

All classifications that indicate a percentage of the fringe benefits must be calculated at the percentage rate times the "base hourly rate".

Apprentices duly registered under the Commissioner of Labor's regulations on "Work Training Standards for Apprenticeship and Training Programs" Section 31-51-d-1 to 12, are allowed to be paid the appropriate percentage of the prevailing journeymen hourly base and the full fringe benefit rate, providing the work site ratio shall not be less than one full-time journeyman instructing and supervising the work of each apprentice in a specific trade.

~~Connecticut General Statute Section 31-55a: Annual Adjustments to wage rates by contractors doing state work ~~

The Prevailing wage rates applicable to this project are subject to annual adjustments each July 1st for the duration of the project.

Each contractor shall pay the annual adjusted prevailing wage rate that is in effect each July 1st, as posted by the Department of Labor.

It is the contractor's responsibility to obtain the annual adjusted prevailing wage rate increases directly from the Department of Labor's website.

The annual adjustments will be posted on the Department of Labor's Web page: www.ct.gov/dol.

The Department of Labor will continue to issue the initial prevailing wage rate schedule to the Contracting Agency for the project.

All subsequent annual adjustments will be posted on our Web Site for contractor access.

Contracting Agencies are under no obligation pursuant to State labor law to pay any increase due to the annual adjustment provision.

As of:

Friday, April 24, 2015

Project: Road Paving Program

Effective October 1, 2005 - Public Act 05-50: any person performing the work of any mechanic, laborer, or worker shall be paid prevailing wage

All Person who perform work ON SITE must be paid prevailing wage for the appropriate mechanic, laborer, or worker classification.

All certified payrolls must list the hours worked and wages paid to All Persons who perform work ON SITE regardless of their ownership i.e.: (Owners, Corporate Officers, LLC Members, Independent Contractors, et. al)

Reporting and payment of wages is required regardless of any contractual relationship alleged to exist between the contractor and such person.

~~Unlisted classifications needed for work not included within the scope of the classifications listed may be added after award only as provided in the labor standards contract clause (29 CFR 5.5 (a) (1) (ii)).

Please direct any questions which you may have pertaining to classification of work and payment of prevailing wages to the Wage and Workplace Standards Division, telephone (860)263-6790.

As of:

Friday, April 24, 2015

STATUTE 31-55a

- SPECIAL NOTICE -

To: All State and Political Subdivisions, Their Agents, and Contractors

Connecticut General Statute 31-55a - Annual adjustments to wage rates by contractors doing state work.

Each contractor that is awarded a contract on or after October 1, 2002, for (1) the construction of a state highway or bridge that falls under the provisions of section 31-54 of the general statutes, or (2) the construction, remodeling, refinishing, refurbishing, rehabilitation, alteration or repair of any public works project that falls under the provisions of section 31-53 of the general statutes shall contact the Labor Commissioner on or before July first of each year, for the duration of such contract, to ascertain the prevailing rate of wages on an hourly basis and the amount of payment or contributions paid or payable on behalf of each mechanic, laborer or worker employed upon the work contracted to be done, and shall make any necessary adjustments to such prevailing rate of wages and such payment or contributions paid or payable on behalf of each such employee, effective each July first.

- The prevailing wage rates applicable to any contract or subcontract awarded on or after October 1, 2002 are subject to annual adjustments each July 1st for the duration of any project which was originally advertised for bids on or after October 1, 2002.
- Each contractor affected by the above requirement shall pay the annual adjusted prevailing wage rate that is in effect each July 1st, as posted by the Department of Labor.
- It is the **contractor's** responsibility to obtain the annual adjusted prevailing wage rate increases directly from the Department of Labor's Web Site. The annual adjustments will be posted on the Department of Labor Web page: www.ctdol.state.ct.us. For those without internet access, please contact the division listed below.
- The Department of Labor will continue to issue the initial prevailing wage rate schedule to the Contracting Agency for the project. All subsequent annual adjustments will be posted on our Web Site for contractor access.

Any questions should be directed to the Contract Compliance Unit, Wage and Workplace Standards Division, Connecticut Department of Labor, 200 Folly Brook Blvd., Wethersfield, CT 06109 at (860)263-6790.

Sec. 31-53b. Construction safety and health course. New miner training program. Proof of completion required for mechanics, laborers and workers on public works projects. Enforcement. Regulations. Exceptions. (a) Each contract for a public works project entered into on or after July 1, 2009, by the state or any of its agents, or by any political subdivision of the state or any of its agents, described in subsection (g) of section 31-53, shall contain a provision requiring that each contractor furnish proof with the weekly certified payroll form for the first week each employee begins work on such project that any person performing the work of a mechanic, laborer or worker pursuant to the classifications of labor under section 31-53 on such public works project, pursuant to such contract, has completed a course of at least ten hours in duration in construction safety and health approved by the federal Occupational Safety and Health Administration or, has completed a new miner training program approved by the Federal Mine Safety and Health Administration in accordance with 30 CFR 48 or, in the case of telecommunications employees, has completed at least ten hours of training in accordance with 29 CFR 1910.268.

(b) Any person required to complete a course or program under subsection (a) of this section who has not completed the course or program shall be subject to removal from the worksite if the person does not provide documentation of having completed such course or program by the fifteenth day after the date the person is found to be in noncompliance. The Labor Commissioner or said commissioner's designee shall enforce this section.

(c) Not later than January 1, 2009, the Labor Commissioner shall adopt regulations, in accordance with the provisions of chapter 54, to implement the provisions of subsections (a) and (b) of this section. Such regulations shall require that the ten-hour construction safety and health courses required under subsection (a) of this section be conducted in accordance with federal Occupational Safety and Health Administration Training Institute standards, or in accordance with Federal Mine Safety and Health Administration Standards or in accordance with 29 CFR 1910.268, as appropriate. The Labor Commissioner shall accept as sufficient proof of compliance with the provisions of subsection (a) or (b) of this section a student course completion card issued by the federal Occupational Safety and Health Administration Training Institute, or such other proof of compliance said commissioner deems appropriate, dated no earlier than five years before the commencement date of such public works project.

(d) This section shall not apply to employees of public service companies, as defined in section 16-1, or drivers of commercial motor vehicles driving the vehicle on the public works project and delivering or picking up cargo from public works projects provided they perform no labor relating to the project other than the loading and unloading of their cargo.

(P.A. 06-175, S. 1; P.A. 08-83, S. 1.)

History: P.A. 08-83 amended Subsec. (a) by making provisions applicable to public works project contracts entered into on or after July 1, 2009, replacing provision re total cost of work with reference to Sec. 31-53(g), requiring proof in certified payroll form that new mechanic, laborer or worker has completed a 10-hour or more construction safety course and adding provision re new miner training program, amended Subsec. (b) by substituting "person" for "employee" and adding "or program", amended Subsec. (c) by adding "or in accordance with Federal Mine Safety and Health Administration Standards" and setting new deadline of January 1, 2009, deleted former Subsec. (d) re "public building", added new Subsec. (d) re exemptions for public service company employees and delivery drivers who perform no labor other than delivery and made conforming and technical changes, effective January 1, 2009.

~NOTICE~

TO ALL CONTRACTING AGENCIES

Please be advised that Connecticut General Statutes Section 31-53, requires the contracting agency to certify to the Department of Labor, the total dollar amount of work to be done in connection with such public works project, regardless of whether such project consists of one or more contracts.

Please find the attached “Contracting Agency Certification Form” to be completed and returned to the Department of Labor, Wage and Workplace Standards Division, Public Contract Compliance Unit.

 Inquiries can be directed to (860)263-6543.

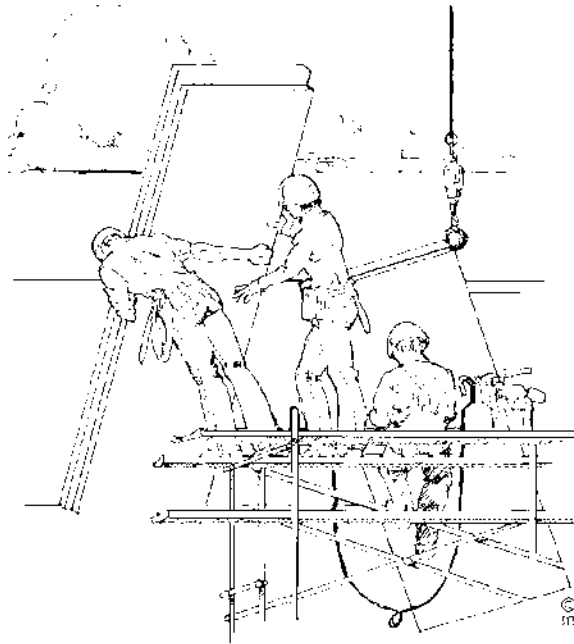

CONNECTICUT DEPARTMENT OF LABOR
WAGE AND WORKPLACE STANDARDS DIVISION
CONTRACT COMPLIANCE UNIT

CONTRACTING AGENCY CERTIFICATION FORM

I, _____, acting in my official capacity as _____,
authorized representative title

for _____, located at _____,
contracting agency address

do hereby certify that the total dollar amount of work to be done in connection with
_____, located at _____,
project name and number address

shall be \$_____, which includes all work, regardless of whether such project
consists of one or more contracts.

CONTRACTOR INFORMATION

Name: _____

Address: _____

Authorized Representative: _____

Approximate Starting Date: _____

Approximate Completion Date: _____

Signature

Date

Return To: Connecticut Department of Labor
Wage & Workplace Standards Division
Contract Compliance Unit
200 Folly Brook Blvd.
Wethersfield, CT 06109

Date Issued: _____

CONNECTICUT DEPARTMENT OF LABOR
WAGE AND WORKPLACE STANDARDS DIVISION

CONTRACTORS WAGE CERTIFICATION FORM
Construction Manager at Risk/General Contractor/Prime Contractor

I, _____ of _____
Officer, Owner, Authorized Rep. Company Name

do hereby certify that the _____
Company Name

Street

City

and all of its subcontractors will pay all workers on the

Project Name and Number

Street and City

the wages as listed in the schedule of prevailing rates required for such project (a copy of which is attached hereto).

Signed

Subscribed and sworn to before me this _____ day of _____, _____.

Notary Public

Return to:
Connecticut Department of Labor
Wage & Workplace Standards Division
200 Folly Brook Blvd.
Wethersfield, CT 06109

Rate Schedule Issued (Date): _____

**Connecticut Department of Labor
Wage and Workplace Standards Division
FOOTNOTES**

⇒ Please Note: If the “Benefits” listed on the schedule for the following occupations includes a letter(s) (+ a or + a+b for instance), refer to the information below.

Benefits to be paid at the appropriate prevailing wage rate for the listed occupation.

If the “Benefits” section for the occupation lists only a dollar amount, disregard the information below.

**Bricklayers, Cement Masons, Cement Finishers, Concrete Finishers, Stone Masons
(Building Construction) and
(Residential- Hartford, Middlesex, New Haven, New London and Tolland Counties)**

- a. Paid Holiday: Employees shall receive 4 hours for Christmas Eve holiday provided the employee works the regularly scheduled day before and after the holiday. Employers may schedule work on Christmas Eve and employees shall receive pay for actual hours worked in addition to holiday pay.

Elevator Constructors: Mechanics

- a. Paid Holidays: New Year’s Day, Memorial Day, Independence Day, Labor Day, Veterans’ Day, Thanksgiving Day, Christmas Day, plus the Friday after Thanksgiving.
- b. Vacation: Employer contributes 8% of basic hourly rate for 5 years or more of service or 6% of basic hourly rate for 6 months to 5 years of service as vacation pay credit.

Glaziers

- a. Paid Holidays: Labor Day and Christmas Day.

**Power Equipment Operators
(Heavy and Highway Construction & Building Construction)**

- a. Paid Holidays: New Year’s Day, Good Friday, Memorial day, Independence Day, Labor Day, Thanksgiving Day and Christmas Day, provided the employee works 3 days during the week in which the holiday falls, if scheduled, and if scheduled, the working day before and the working day after the holiday. Holidays falling on Saturday may be observed on Saturday, or if the employer so elects, on the preceding Friday.

Ironworkers

- a. Paid Holiday: Labor Day provided employee has been on the payroll for the 5 consecutive work days prior to Labor Day.

Laborers (Tunnel Construction)

- a. Paid Holidays: New Year's Day, Memorial Day, Independence Day, Labor Day, Thanksgiving Day and Christmas Day. No employee shall be eligible for holiday pay when he fails, without cause, to work the regular work day preceding the holiday or the regular work day following the holiday.

Roofers

- a. Paid Holidays: July 4th, Labor Day, and Christmas Day provided the employee is employed 15 days prior to the holiday.

Sprinkler Fitters

- a. Paid Holidays: Memorial Day, July 4th, Labor Day, Thanksgiving Day and Christmas Day, provided the employee has been in the employment of a contractor 20 working days prior to any such paid holiday.

Truck Drivers

(Heavy and Highway Construction & Building Construction)

- a. Paid Holidays: New Year's Day, Memorial Day, Independence Day, Labor Day, Thanksgiving Day, Christmas day, and Good Friday, provided the employee has at least 31 calendar days of service and works the last scheduled day before and the first scheduled day after the holiday, unless excused.

Informational Bulletin

THE 10-HOUR OSHA CONSTRUCTION SAFETY AND HEALTH COURSE

(applicable to public building contracts entered into *on or after July 1, 2007*, where the total cost of all work to be performed is at least \$100,000)

- (1) This requirement was created by Public Act No. 06-175, which is codified in Section 31-53b of the Connecticut General Statutes (pertaining to the prevailing wage statutes);
- (2) The course is required for public building construction contracts (projects funded in whole or in part by the state or any political subdivision of the state) entered into on or after July 1, 2007;
- (3) It is required of private employees (not state or municipal employees) and apprentices who perform manual labor for a general contractor or subcontractor on a public building project where the total cost of all work to be performed is at least \$100,000;
- (4) The ten-hour construction course pertains to the ten-hour Outreach Course conducted in accordance with federal OSHA Training Institute standards, and, for telecommunications workers, a ten-hour training course conducted in accordance with federal OSHA standard, 29 CFR 1910.268;
- (5) The internet website for the federal OSHA Training Institute is http://www.osha.gov/fso/ote/training/edcenters/fact_sheet.html;
- (6) The statutory language leaves it to the contractor and its employees to determine who pays for the cost of the ten-hour Outreach Course;
- (7) Within 30 days of receiving a contract award, a general contractor must furnish proof to the Labor Commissioner that all employees and apprentices performing manual labor on the project will have completed such a course;
- (8) Proof of completion may be demonstrated through either: (a) the presentation of a *bona fide* student course completion card issued by the federal OSHA Training Institute; *or* (2) the presentation of documentation provided to an employee by a trainer certified by the Institute pending the actual issuance of the completion card;
- (9) Any card with an issuance date more than 5 years prior to the commencement date of the construction project shall not constitute proof of compliance;

- (10) Each employer shall affix a copy of the construction safety course completion card to the certified payroll submitted to the contracting agency in accordance with Conn. Gen. Stat. § 31-53(f) on which such employee's name first appears;
- (11) Any employee found to be in non-compliance shall be subject to removal from the worksite if such employee does not provide satisfactory proof of course completion to the Labor Commissioner by the fifteenth day after the date the employee is determined to be in noncompliance;
- (12) Any such employee who is determined to be in noncompliance may continue to work on a public building construction project for a maximum of fourteen consecutive calendar days while bringing his or her status into compliance;
- (13) The Labor Commissioner may make complaint to the prosecuting authorities regarding any employer or agent of the employer, or officer or agent of the corporation who files a false certified payroll with respect to the status of an employee who is performing manual labor on a public building construction project;
- (14) The statute provides the minimum standards required for the completion of a safety course by manual laborers on public construction contracts; any contractor can exceed these minimum requirements; and
- (15) Regulations clarifying the statute are currently in the regulatory process, and shall be posted on the CTDOL website as soon as they are adopted in final form.
- (16) Any questions regarding this statute may be directed to the Wage and Workplace Standards Division of the Connecticut Labor Department via the internet website of <http://www.ctdol.state.ct.us/wgwkstnd/wgemenu.htm>; or by telephone at (860)263-6790.

THE ABOVE INFORMATION IS PROVIDED EXCLUSIVELY AS AN EDUCATIONAL RESOURCE, AND IS NOT INTENDED AS A SUBSTITUTE FOR LEGAL INTERPRETATIONS WHICH MAY ULTIMATELY ARISE CONCERNING THE CONSTRUCTION OF THE STATUTE OR THE REGULATIONS.

Informational Bulletin

THE 10-HOUR OSHA CONSTRUCTION SAFETY AND HEALTH COURSE

(applicable to public building contracts entered into *on or after July 1, 2007*, where the total cost of all work to be performed is at least \$100,000)

- (1) This requirement was created by Public Act No. 06-175, which is codified in Section 31-53b of the Connecticut General Statutes (pertaining to the prevailing wage statutes);
- (2) The course is required for public building construction contracts (projects funded in whole or in part by the state or any political subdivision of the state) entered into on or after July 1, 2007;
- (3) It is required of private employees (not state or municipal employees) and apprentices who perform manual labor for a general contractor or subcontractor on a public building project where the total cost of all work to be performed is at least \$100,000;
- (4) The ten-hour construction course pertains to the ten-hour Outreach Course conducted in accordance with federal OSHA Training Institute standards, and, for telecommunications workers, a ten-hour training course conducted in accordance with federal OSHA standard, 29 CFR 1910.268;
- (5) The internet website for the federal OSHA Training Institute is http://www.osha.gov/fso/ote/training/edcenters/fact_sheet.html;
- (6) The statutory language leaves it to the contractor and its employees to determine who pays for the cost of the ten-hour Outreach Course;
- (7) Within 30 days of receiving a contract award, a general contractor must furnish proof to the Labor Commissioner that all employees and apprentices performing manual labor on the project will have completed such a course;
- (8) Proof of completion may be demonstrated through either: (a) the presentation of a *bona fide* student course completion card issued by the federal OSHA Training Institute; *or* (2) the presentation of documentation provided to an employee by a trainer certified by the Institute pending the actual issuance of the completion card;
- (9) Any card with an issuance date more than 5 years prior to the commencement date of the construction project shall not constitute proof of compliance;

- (10) Each employer shall affix a copy of the construction safety course completion card to the certified payroll submitted to the contracting agency in accordance with Conn. Gen. Stat. § 31-53(f) on which such employee's name first appears;
- (11) Any employee found to be in non-compliance shall be subject to removal from the worksite if such employee does not provide satisfactory proof of course completion to the Labor Commissioner by the fifteenth day after the date the employee is determined to be in noncompliance;
- (12) Any such employee who is determined to be in noncompliance may continue to work on a public building construction project for a maximum of fourteen consecutive calendar days while bringing his or her status into compliance;
- (13) The Labor Commissioner may make complaint to the prosecuting authorities regarding any employer or agent of the employer, or officer or agent of the corporation who files a false certified payroll with respect to the status of an employee who is performing manual labor on a public building construction project;
- (14) The statute provides the minimum standards required for the completion of a safety course by manual laborers on public construction contracts; any contractor can exceed these minimum requirements; and
- (15) Regulations clarifying the statute are currently in the regulatory process, and shall be posted on the CTDOL website as soon as they are adopted in final form.
- (16) Any questions regarding this statute may be directed to the Wage and Workplace Standards Division of the Connecticut Labor Department via the internet website of <http://www.ctdol.state.ct.us/wgwkstnd/wgemenu.htm>; or by telephone at (860)263-6790.

THE ABOVE INFORMATION IS PROVIDED EXCLUSIVELY AS AN EDUCATIONAL RESOURCE, AND IS NOT INTENDED AS A SUBSTITUTE FOR LEGAL INTERPRETATIONS WHICH MAY ULTIMATELY ARISE CONCERNING THE CONSTRUCTION OF THE STATUTE OR THE REGULATIONS.

November 29, 2006

Notice
To All Mason Contractors and Interested Parties
Regarding Construction Pursuant to Section 31-53 of the
Connecticut General Statutes (Prevailing Wage)

The Connecticut Labor Department Wage and Workplace Standards Division is empowered to enforce the prevailing wage rates on projects covered by the above referenced statute.

Over the past few years the Division has withheld enforcement of the rate in effect for workers who operate a forklift on a prevailing wage rate project due to a potential jurisdictional dispute.

The rate listed in the schedules and in our Occupational Bulletin (see enclosed) has been as follows:

Forklift Operator:

- **Laborers (Group 4) Mason Tenders** - operates forklift solely to assist a mason to a maximum height of nine feet only.
- **Power Equipment Operator (Group 9)** - operates forklift to assist any trade and to assist a mason to a height over nine feet.

The U.S. Labor Department conducted a survey of rates in Connecticut but it has not been published and the rate in effect remains as outlined in the above Occupational Bulletin.

Since this is a classification matter and not one of jurisdiction, effective January 1, 2007 the Connecticut Labor Department will enforce the rate on each schedule in accordance with our statutory authority.

Your cooperation in filing appropriate and accurate certified payrolls is appreciated.

***FRINGE BENEFITS EXPLANATION (P):**

Bona fide benefits paid to approved plans, funds or programs, except those required by Federal or State Law (unemployment tax, worker’s compensation, income taxes, etc.).

Please specify the type of benefits provided:

- 1) Medical or hospital care _____ 4) Disability _____
- 2) Pension or retirement _____ 5) Vacation, holiday _____
- 3) Life Insurance _____ 6) Other (please specify) _____

CERTIFIED STATEMENT OF COMPLIANCE

For the week ending date of _____,

I, _____ of _____, (hereafter known as Employer) in my capacity as _____ (title) do hereby certify and state:

Section A:

1. All persons employed on said project have been paid the full weekly wages earned by them during the week in accordance with Connecticut General Statutes, section 31-53, as amended. Further, I hereby certify and state the following:

- a) The records submitted are true and accurate;
- b) The rate of wages paid to each mechanic, laborer or workman and the amount of payment or contributions paid or payable on behalf of each such person to any employee welfare fund, as defined in Connecticut General Statutes, section 31-53 (h), are not less than the prevailing rate of wages and the amount of payment or contributions paid or payable on behalf of each such person to any employee welfare fund, as determined by the Labor Commissioner pursuant to subsection Connecticut General Statutes, section 31-53 (d), and said wages and benefits are not less than those which may also be required by contract;
- c) The Employer has complied with all of the provisions in Connecticut General Statutes, section 31-53 (and Section 31-54 if applicable for state highway construction);
- d) Each such person is covered by a worker’s compensation insurance policy for the duration of his employment which proof of coverage has been provided to the contracting agency;
- e) The Employer does not receive kickbacks, which means any money, fee, commission, credit, gift, gratuity, thing of value, or compensation of any kind which is provided directly or indirectly, to any prime contractor, prime contractor employee, subcontractor, or subcontractor employee for the purpose of improperly obtaining or rewarding favorable treatment in connection with a prime contract or in connection with a prime contractor in connection with a subcontractor relating to a prime contractor; and
- f) The Employer is aware that filing a certified payroll which he knows to be false is a class D felony for which the employer may be fined up to five thousand dollars, imprisoned for up to five years or both.

2. OSHA~The employer shall affix a copy of the construction safety course, program or training completion document to the certified payroll required to be submitted to the contracting agency for this project on which such persons name first appears.

_____ Submitted on (Date)

(Signature) (Title)

[New] In accordance with Section 31-53b(a) of the C.G.S. each contractor shall provide a copy of the OSHA 10 Hour Construction Safety and Health Card for each employee, to be attached to the first certified payroll on the project.

PAYROLL CERTIFICATION FOR PUBLIC WORKS PROJECTS											Connecticut Department of Labor Wage and Workplace Standards Division 200 Folly Brook Blvd. Wethersfield, CT 06109										
In accordance with Connecticut General Statutes, 31-53 Certified Payrolls with a statement of compliance shall be submitted monthly to the contracting agency.											WEEKLY PAYROLL										
CONTRACTOR NAME AND ADDRESS: Landon Corporation, 15 Connecticut Avenue, Northford, CT 06472						SUBCONTRACTOR NAME & ADDRESS XYZ Corporation 2 Main Street Yantic, CT 06389					WORKER'S COMPENSATION INSURANCE CARRIER Travelers Insurance Company POLICY # #BAC8888928 EFFECTIVE DATE: 1/1/09 EXPIRATION DATE: 12/31/09										
PAYROLL NUMBER	Week-Ending Date	PROJECT NAME & ADDRESS									Total ST Hours	BASE HOURLY RATE	TYPE OF FRINGE BENEFITS Per Hour 1 through 6 (see back)	GROSS PAY FOR ALL WORK PERFORMED THIS WEEK	TOTAL DEDUCTIONS				GROSS PAY FOR THIS PREVAILING RATE JOB	CHECK # AND NET PAY	
		DAY AND DATE							Total O/T Hours	TOTAL FRINGE BENEFIT PLAN CASH					FICA	FEDERAL WITH-HOLDING	STATE WITH-HOLDING	LIST OTHER			
PERSON/WORKER, ADDRESS and SECTION	APPR RATE %	MALE/FEMALE AND RACE*	WORK CLASSIFICATION	S	M	T	W	TH			F	S									
			Trade License Type & Number - OSHA 10 Certification Number	20	21	22	23	24	25	26											
HOURS WORKED EACH DAY																					
Robert Craft 81 Maple Street Willimantic, CT 06226		M/C	Electrical Lineman E-1 1234567 Owner OSHA 123456		8	8	8	8	8			S-TIME 40	\$ 30.75 Base Rate	1. \$ 5.80 2. \$ 3. \$ 2.01	\$1,582.80				P-xxxx	\$1,582.80	#123 \$ xxx.xx
Ronald Jones 212 Elm Street Norwich, CT 06360	65%	M/B	Electrical Apprentice OSHA 234567		8	8	8	8	8			S-TIME 40	\$ 19.99 Base Rate	1. \$ 2. \$ 3. \$ 4. \$ 5. \$ 6. \$	\$1,464.80	xx.xx	xxx.xx	xx.xx	G-xxx	\$1,464.80	#124 \$xxx.xx
Franklin T. Smith 234 Washington Rd. New London, CT 06320 SECTION B		M/H	Project Manager			8						S-TIME 8	\$ Base Rate	1. \$ 2. \$ 3. \$ 4. \$ 5. \$ 6. \$	\$1,500.00	xx.xx	xx.xx	xx.xx	M-xx.x		xxx.xx #125
												S-TIME	\$ Base Rate	1. \$ 2. \$ 3. \$ 4. \$ 5. \$ 6. \$							
												O-TIME	\$ Cash Fringe								

7/13/2009 *IF REQUIRED
WWS-CP1

*SEE REVERSE SIDE

PAGE NUMBER 1 OF 2

OSHA 10 ~ATTACH CARD TO 1ST CERTIFIED PAYROLL

***FRINGE BENEFITS EXPLANATION (P):**

Bona fide benefits paid to approved plans, funds or programs, except those required by Federal or State Law (unemployment tax, worker's compensation, income taxes, etc.).

Please specify the type of benefits provided:

- 1) Medical or hospital care Blue Cross 4) Disability _____
- 2) Pension or retirement _____ 5) Vacation, holiday _____
- 3) Life Insurance Utopia 6) Other (please specify) _____

CERTIFIED STATEMENT OF COMPLIANCE

For the week ending date of 9/26/09,

I, Robert Craft of XYZ Corporation, (hereafter known as

Employer) in my capacity as Owner (title) do hereby certify and state:

Section A:

1. All persons employed on said project have been paid the full weekly wages earned by them during the week in accordance with Connecticut General Statutes, section 31-53, as amended. Further, I hereby certify and state the following:

- a) The records submitted are true and accurate;
- b) The rate of wages paid to each mechanic, laborer or workman and the amount of payment or contributions paid or payable on behalf of each such employee to any employee welfare fund, as defined in Connecticut General Statutes, section 31-53 (h), are not less than the prevailing rate of wages and the amount of payment or contributions paid or payable on behalf of each such employee to any employee welfare fund, as determined by the Labor Commissioner pursuant to subsection Connecticut General Statutes, section 31-53 (d), and said wages and benefits are not less than those which may also be required by contract;
- c) The Employer has complied with all of the provisions in Connecticut General Statutes, section 31-53 (and Section 31-54 if applicable for state highway construction);
- d) Each such employee of the Employer is covered by a worker's compensation insurance policy for the duration of his employment which proof of coverage has been provided to the contracting agency;
- e) The Employer does not receive kickbacks, which means any money, fee, commission, credit, gift, gratuity, thing of value, or compensation of any kind which is provided directly or indirectly, to any prime contractor, prime contractor employee, subcontractor, or subcontractor employee for the purpose of improperly obtaining or rewarding favorable treatment in connection with a prime contract or in connection with a prime contractor in connection with a subcontractor relating to a prime contractor; and
- f) The Employer is aware that filing a certified payroll which he knows to be false is a class D felony for which the employer may be fined up to five thousand dollars, imprisoned for up to five years or both.

2. OSHA~The employer shall affix a copy of the construction safety course, program or training completion document to the certified payroll required to be submitted to the contracting agency for this project on which such employee's name first appears.

Robert Craft owner 10/2/09
 (Signature) (Title) Submitted on (Date)

Section B: Applies to CONNDOT Projects ONLY

That pursuant to CONNDOT contract requirements for reporting purposes only, all employees listed under Section B who performed work on this project are not covered under the prevailing wage requirements defined in Connecticut General Statutes Section 31-53.

Robert Craft owner 10/2/09
 (Signature) (Title) Submitted on (Date)

Note: CTDOL will assume all hours worked were performed under Section A unless clearly delineated as Section B WWS-CP1 as such. Should an employee perform work under both Section A and Section B, the hours worked and wages paid must be segregated for reporting purposes.

*****THIS IS A PUBLIC DOCUMENT***
DO NOT INCLUDE SOCIAL SECURITY NUMBERS**



Opportunity * Guidance * Support



THIS IS A PUBLIC WORKS PROJECT

Covered by the

PREVAILING WAGE LAW

CT General Statutes Section 31-53

**If you have QUESTIONS regarding your wages
CALL (860) 263-6790**

Section 31-55 of the CT State Statutes requires every contractor or subcontractor performing work for the state to post in a prominent place the prevailing wages as determined by the Labor Commissioner.

SECTION L

Sidwalk Details

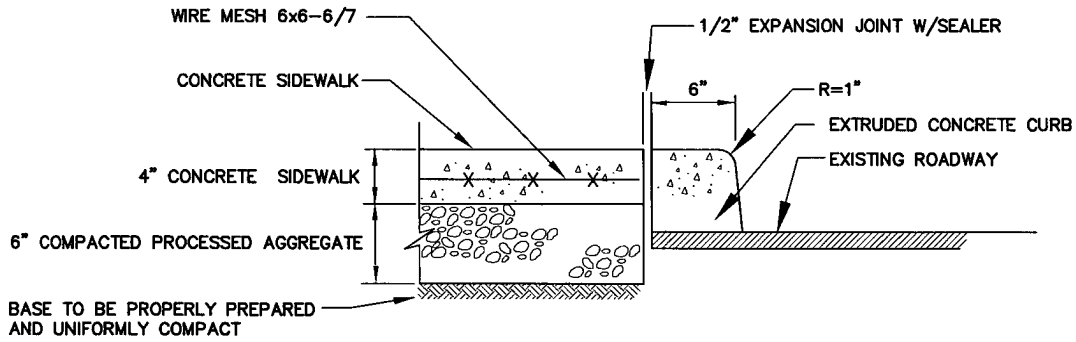

EXTRUDED CONCRETE CURB AND WALK DETAIL

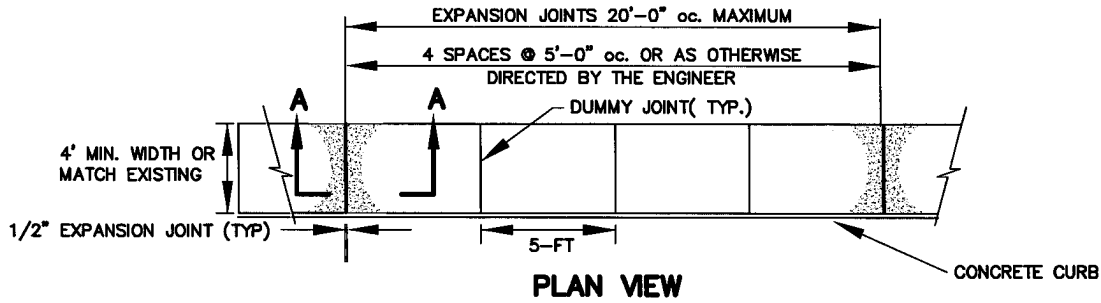

PLAN VIEW

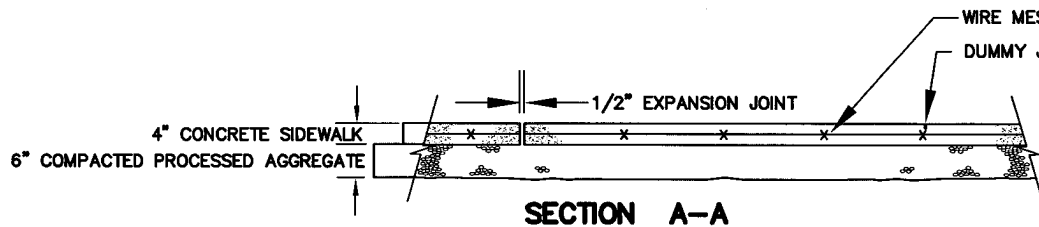

SECTION A-A

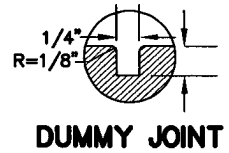

DUMMY JOINT

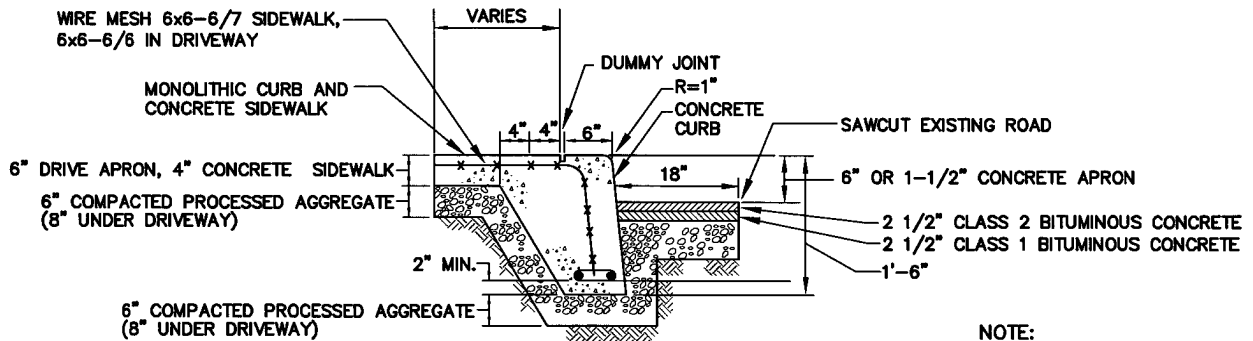

MONOLITHIC CURB AND SIDEWALK DETAIL

NOTE:
ALL CAST CONCRETE
STRUCTURES TO BE CURED IN
ACCORDANCE WITH STANDARD
CURING PRACTICE.

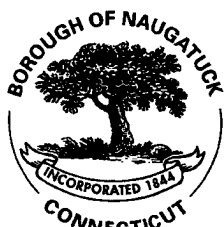

COMBINED CONCRETE SIDEWALK DETAILS

**BOROUGH OF NAUGATUCK
ENGINEERING DEPARTMENT
STANDARD DETAIL**

229 Church Street, Naugatuck, CT 06770

www.naugatuck-ct.gov

Scale: NTS

Drawing No.

SD-48

Date: 10/2011

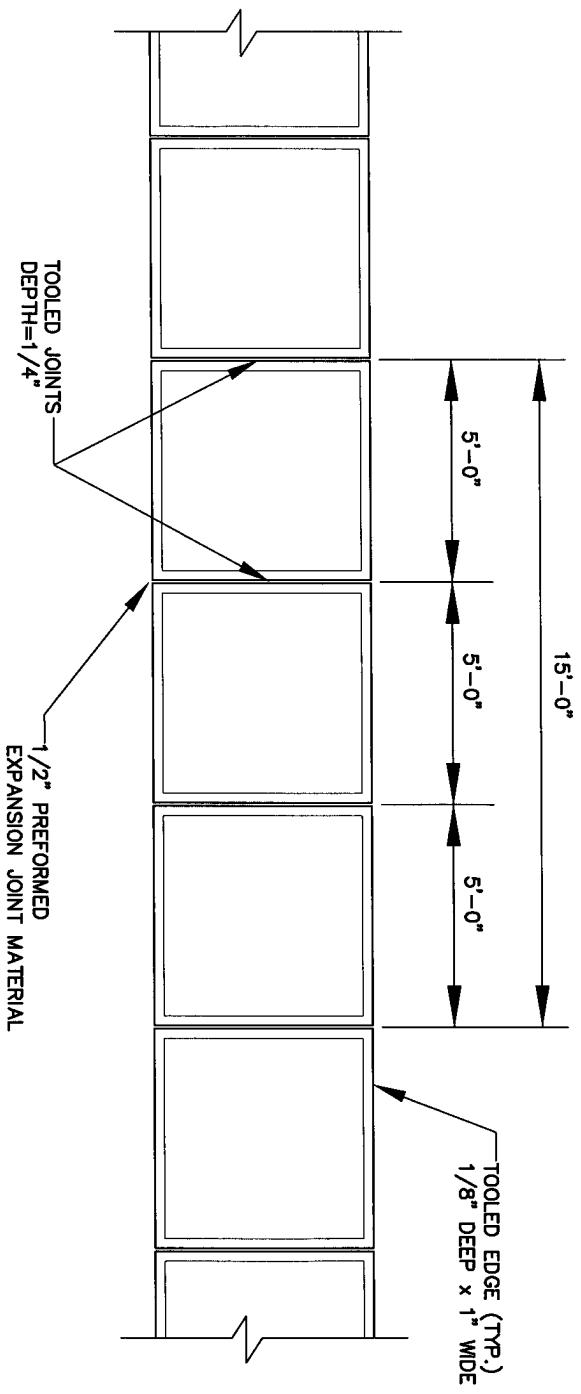

SIDEWALK JOINTS

**BOROUGH OF NAUGATUCK
ENGINEERING DEPARTMENT
STANDARD DETAIL**

229 Church Street, Naugatuck, CT 06770
www.naugatuck-ct.gov

Scale: NTS

Drawing No.
SD-39

Date: 10/2011

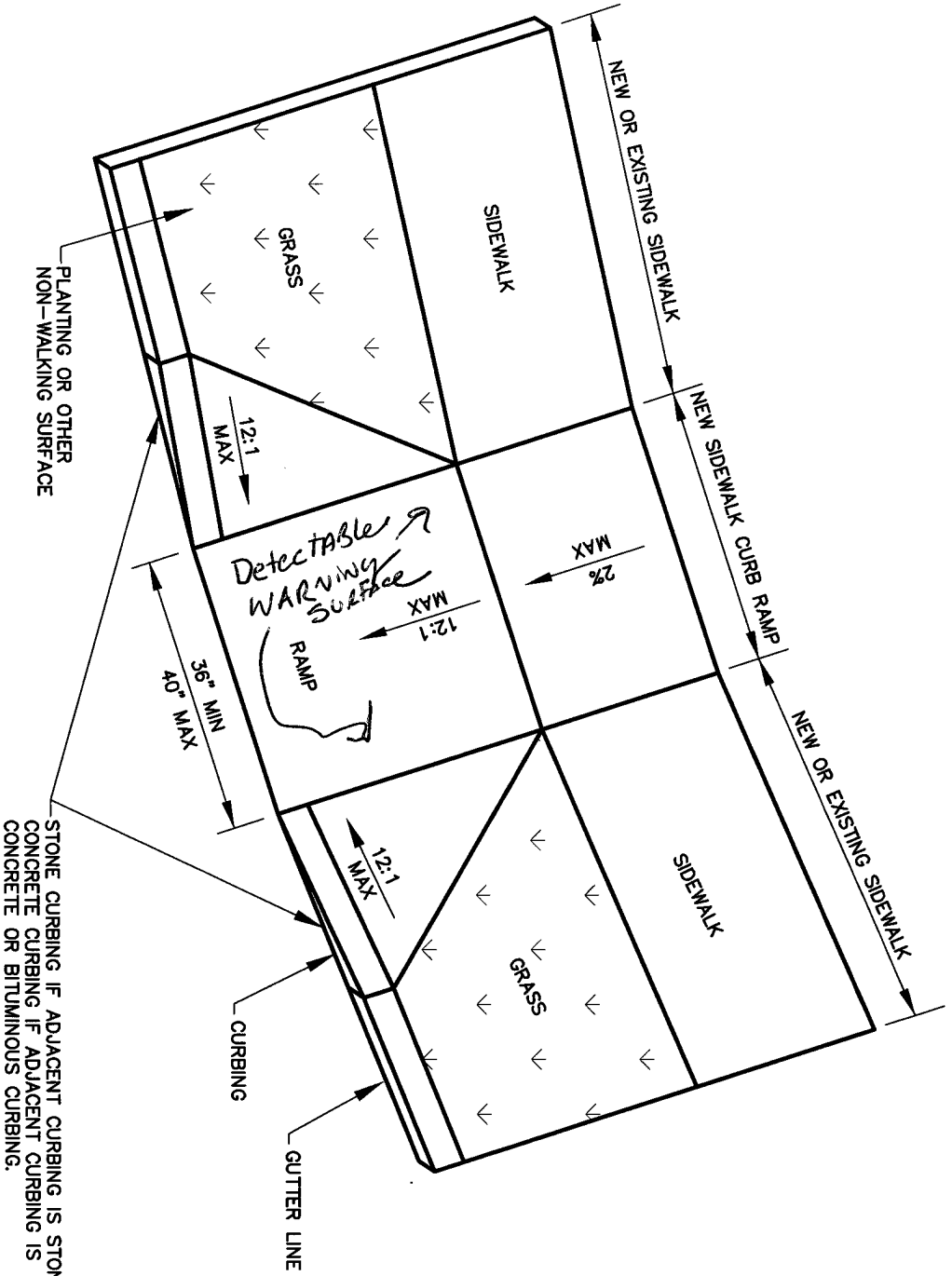

STONE CURBING IF ADJACENT CURBING IS STONE.
 CONCRETE CURBING IF ADJACENT CURBING IS
 CONCRETE OR BITUMINOUS CURBING.



**SIDEWALK CURB RAMP
 CURVED SECTION**

**BOROUGH OF NAUGATUCK
 ENGINEERING DEPARTMENT
 STANDARD DETAIL**

229 Church Street, Naugatuck, CT 06770

www.naugatuck-ct.gov

Scale: NTS

Drawing No.

SD-34

Date: 10/2011

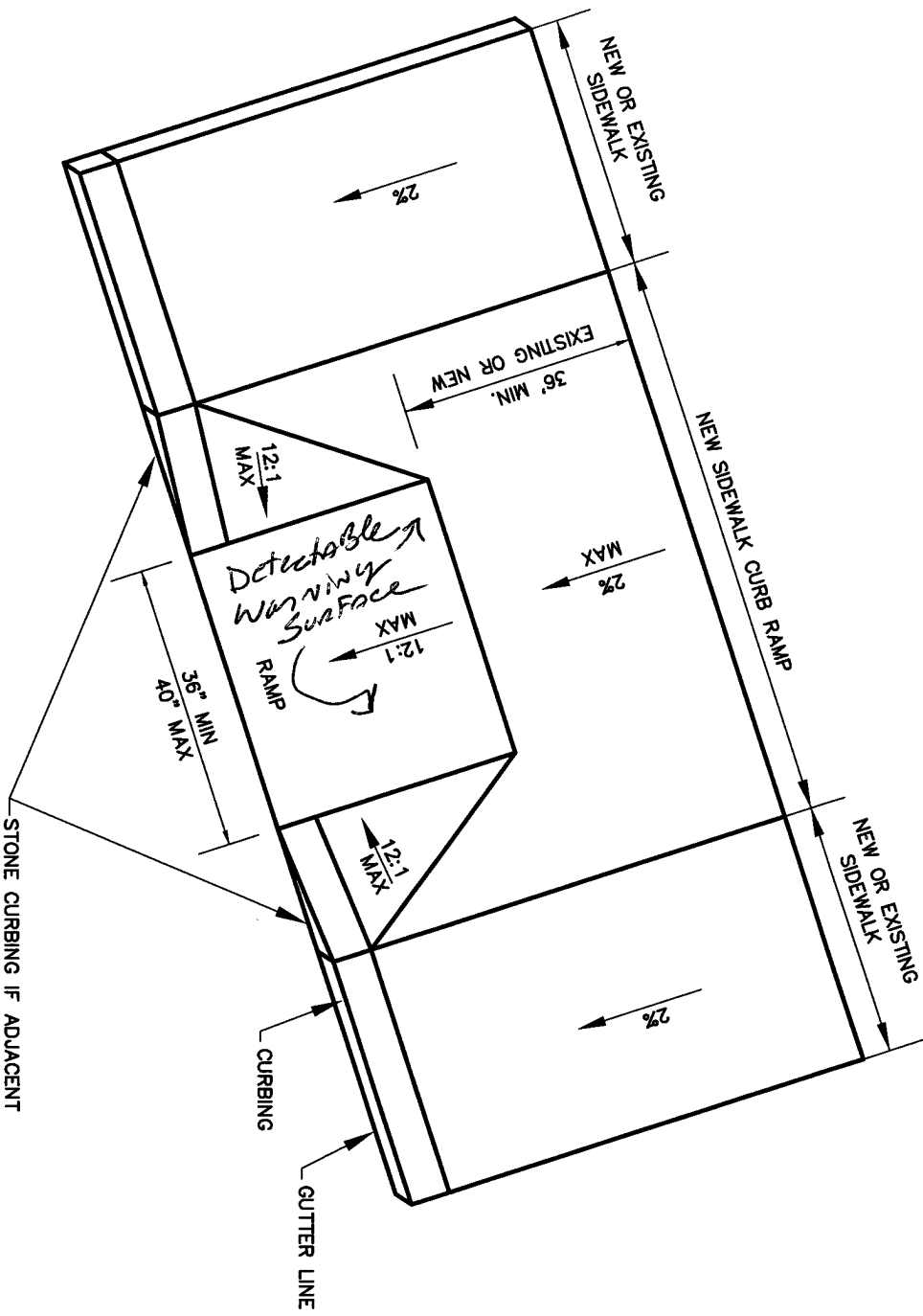

STONE CURBING IF ADJACENT CURBING IS STONE. CONCRETE CURBING IF ADJACENT CURBING IS CONCRETE OR BITUMINOUS CURBING.



SIDEWALK CURB RAMP

**BOROUGH OF NAUGATUCK
ENGINEERING DEPARTMENT
STANDARD DETAIL**

229 Church Street, Naugatuck, CT 06770

www.naugatuck-ct.gov

Scale: NTS

Drawing No.

SD-33

Date: 10/2011